

## USER MANUAL

AUGUST 2016

## LITHIUM BATTERY CHARGER

MM104

A breakout board that incorporates the charger for a single 3.7 volt (4.2 V at full charge) Li-ion element; it is based on the MCP73831T integrated circuit. The card accepts typically a 5V input voltage that can come from a common power supply, from a compact photovoltaic panel or even from a computer USB port. On SOL output contacts it is present a 4.5 to 6 volts voltage, providing the right potential and current required to charge both Li-ion and Li-polymer elements. The battery (to be connected to the +/- BAT contacts) can have a theoretic unlimited capacity, since the limitation depends only by the charging time (that could be really long for high capacity batteries). However, considering that for example a 550 mA current charges a 550 mAh element in one hour, a 1,100 mAh will take 2 hours, a 5.5 Ah will take 10 hours and so on. In the breakout board, the integrated circuit works in the typical configuration that sees the light emitting diode LD1 fed (by the resistance R2 that limits the current) from the STAT output.

Remember that the LED on indicates that battery is charging; if the LED is off, charging is finished or the voltage present on SOL connector is not sufficient to charge the battery. The integrated circuit charges the battery with constant current and voltage.

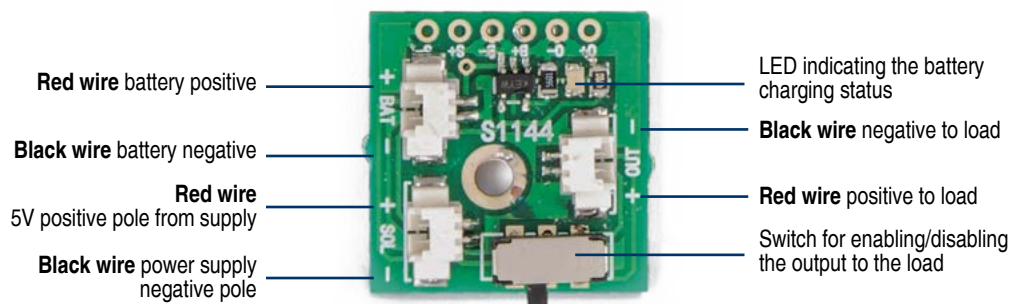

The charging current ( $I_{reg}$ ) is set by the resistance connected to pin 5 (R1 in our case). The current value is reckoned as follows:  
 $I_{reg} = 1000 / R$

where R is in ohms if the  $I_{reg}$  current is expressed in A.

With a R1 resistance by 5.6 KOhm you have a 170mA charging current. If we replace this with a 4.7 KOhm R, the current is 212 mA, while with 2.2 KOhm the current is about 454 mA. If the "5" pin is open, the integrated is sent to a low-consumption state ("shutdown") and dissipates only 2 microAmpere ( $\mu A$ ). The charging procedure follows different phases: once the battery is connected to Vbat output, If the detected voltage is lower than a certain threshold (typically around 70% of the full charge value) a preconditioning charge is started, with a modest current value that is only preparatory to the fast charge phase. The latter phase is initiated when the voltage between battery poles overtakes the above mentioned threshold. The fast charging current is determined, as told before, by the resistor connected to pin 5. As soon as the battery voltage reaches the regulation voltage set on the integrated circuit, it stops charging and starts the maintenance mode, aiming at stabilizing the voltage to 4.2V.

To complete the charger circuit, we have added the SW1 switch, which allows to disconnect the OUT battery output and the MCP73831 output when you want to disconnect the load, so until the battery itself is not charged enough.

It has been given the possibility to access to all onboard connectors or to mount the breakout board by using a pin-strip (on the PCB there are dedicated areas) on other boards.

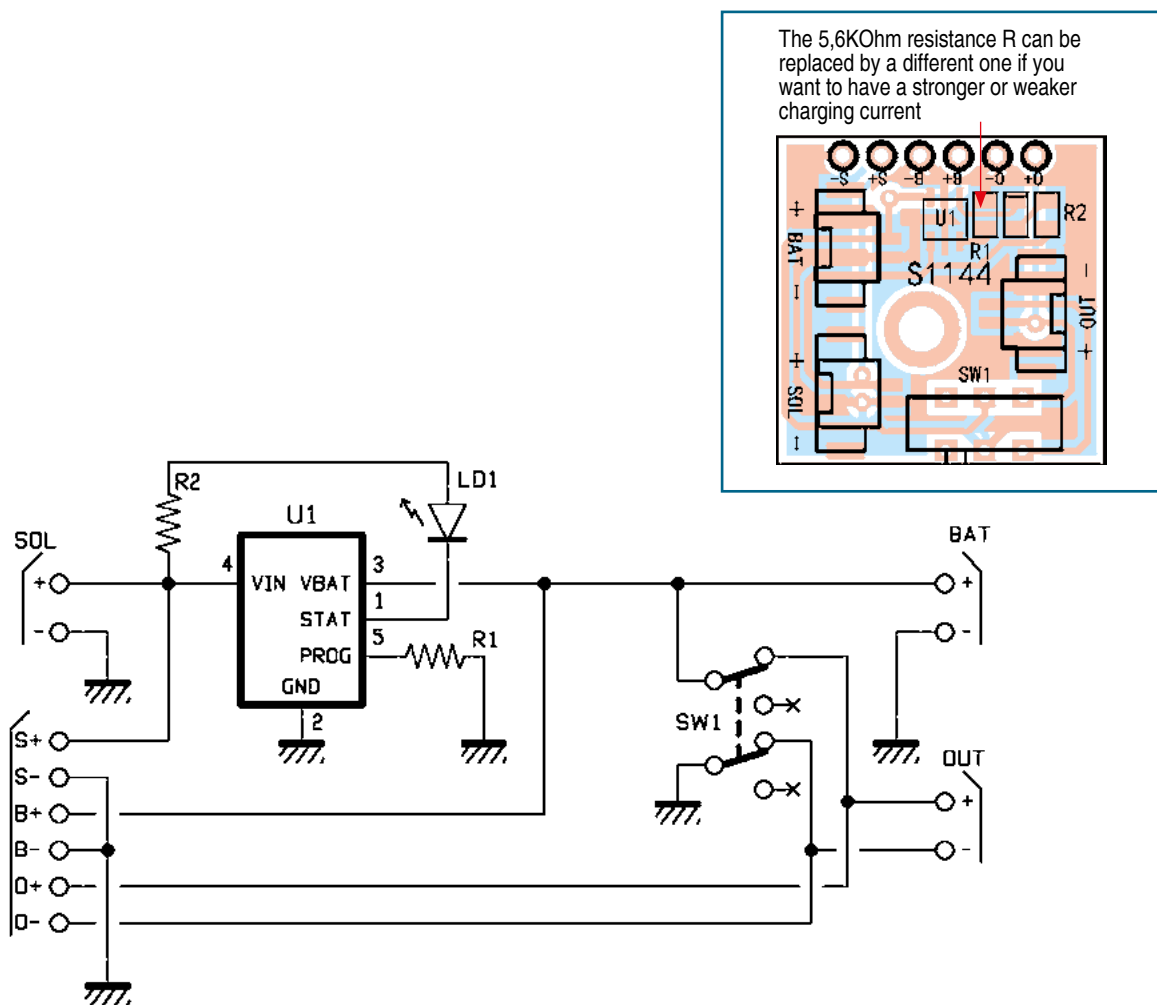

WWW.VELLEMANPROJECTS.EU



VellemanProjects



@Vel\_Projects

VELLEMAN nv - Legen Heirweg 33, Gavere (Belgium)  
 vellemanprojects.com