

TWIN-MOTOR GEARBOX KIT

- ◆ Two motor and gear sets to have wheels running in different direction.
- ◆ 3 kinds gear ratio and output for your choice.
- ◆ Wheels, tires and all other necessary parts included.
- ◆ Easy to follow instruction manual included.

Tools You May Need

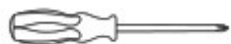

+ Screwdriver



Pliers



Side Cutter

Gear Ratio

A 1:60

/200

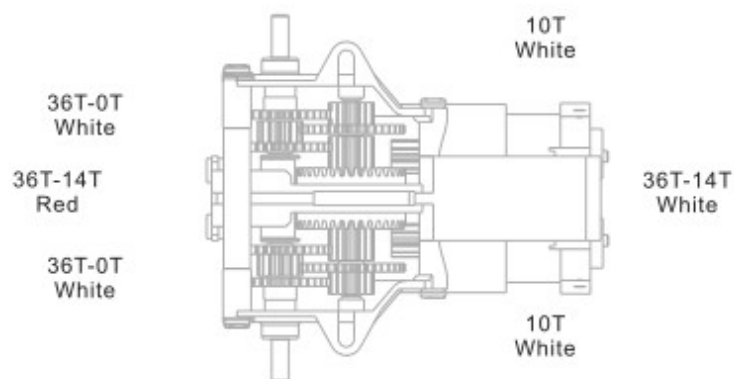

USER MANUAL

TWIN-MOTOR GEARBOX KIT

- 2 motor and 3 gear sets to have wheels running in different directions
- 3 kinds of gear ratio and output
- wheels, tires and all other necessary parts included

Tools you may need

- + screwdriver
- pliers
- side cutter

Gear Ratio

B 1:120 Gear ratio / 100 RPM output

1:120 gear ratio / 100 RPM output

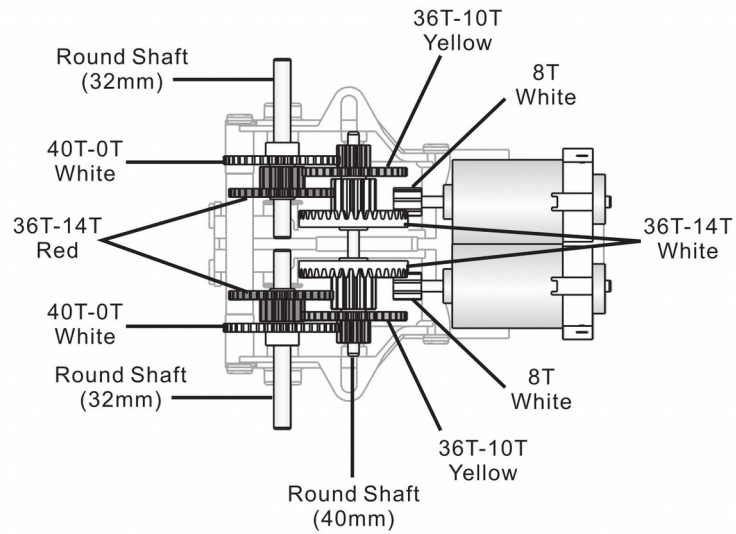

C 1:288 Gear ratio / 42 RPM output

1:288 gear ratio / 42 RPM output

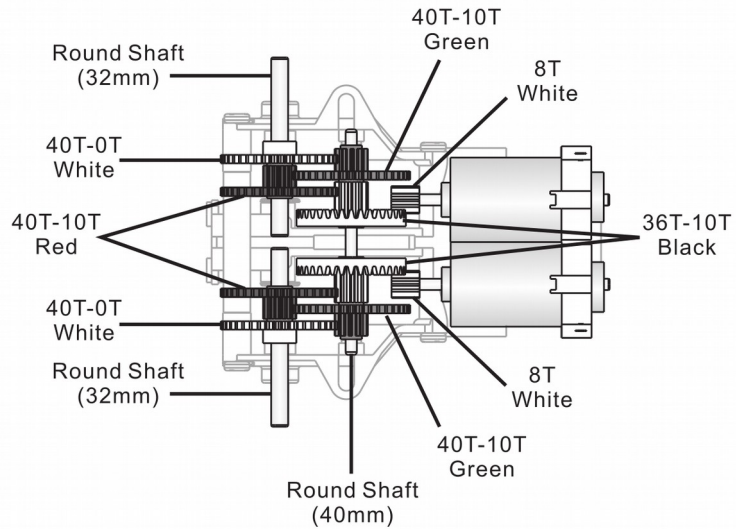

Plastic Part

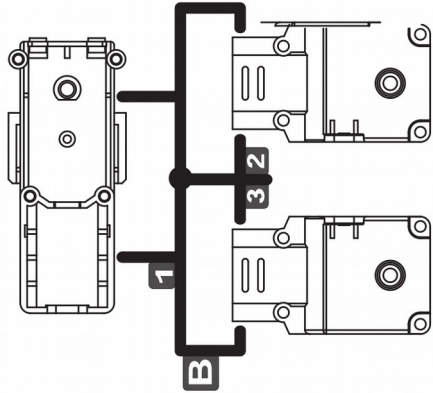

Plastic Part

Gear Box Assembly

STEP
1





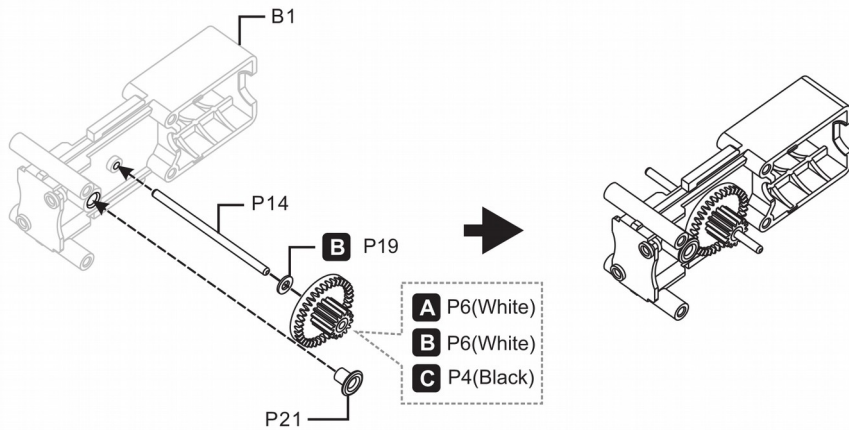





















A 1:60 **B** 1:120 **C** 1:288



Gear Box Assembly

Mechanical Parts List

P1	Motor	Qty		P2	Gear 8T	Qty		P3	Gear 10T	Qty		P4	Gear 36T/10T	Qty	
		2			 White (small)	2			 White (big)	2			 Black	2	
P5	Gear 36T/10T	Qty		P6	Gear 36T/14T	Qty		P7	Gear 36T/14T	Qty		P8	Gear 40T/10T	Qty	
	 Yellow	2			 White	2			 Red (small)	2			 Red (big)	2	
P9	Gear 36T/14T	Qty		P10	Gear 40T/10T	Qty		P11	Gear 36T/0T	Qty		P12	Gear 40T/0T	Qty	
	 Green (small)	2			 Green (big)	2			 White (small)	2			 White (big)	2	
P13	Nylon Connector	Qty		P14	Round Shaft	Qty		P15	Tapping Screw	Qty		P16	Machine Screw	Qty	
		2			 40mm	1				8 (2.6x14)				2 (2.6x10)	
P17	Tapping Screw	Qty		P18	Tapping Screw	Qty		P19	Washer	Qty		P20	Nut	Qty	
		2 (2.6x6)				2 (2.6x6)				2				2	
P21	Eyelet	Qty		P22	Round Spacer	Qty		P23	Wheel	Qty		P24	Tire	Qty	
		4				2				2				2	

Mechanical Parts List

STEP 2



A 1:60 **B** 1:120 **C** 1:288

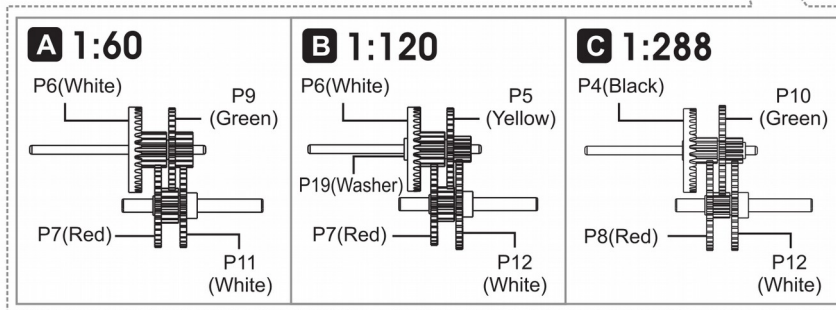
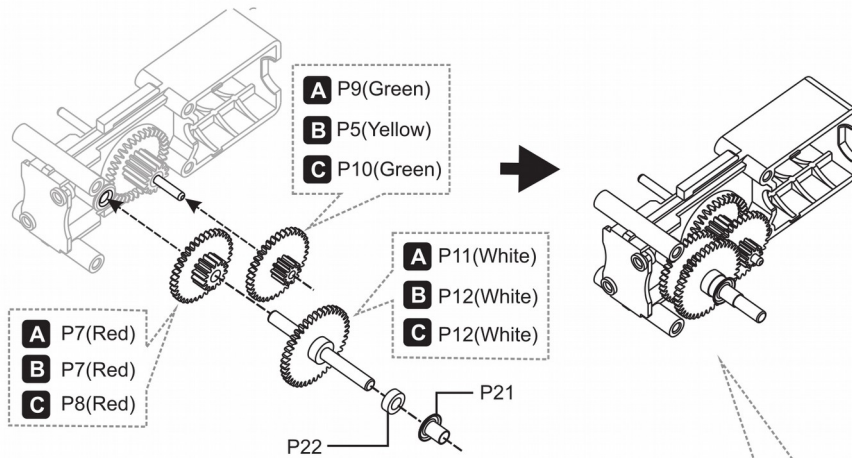

STEP 3

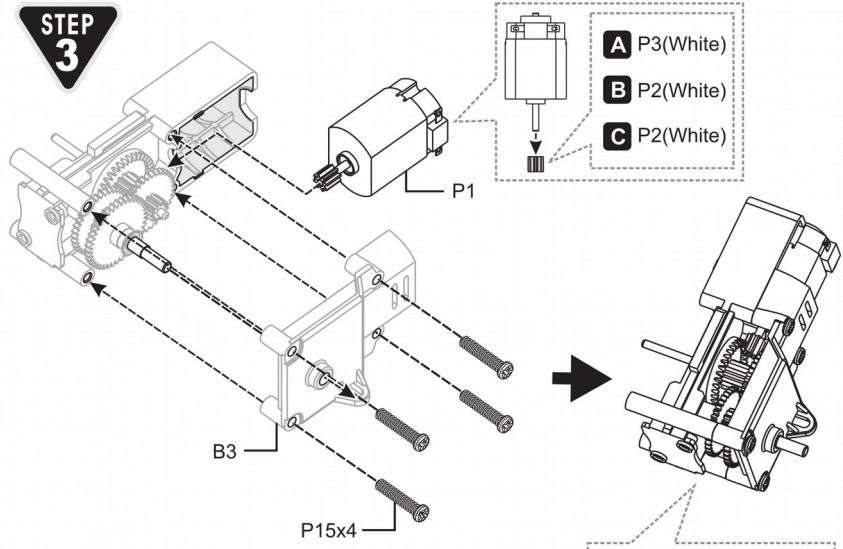

STEP 4

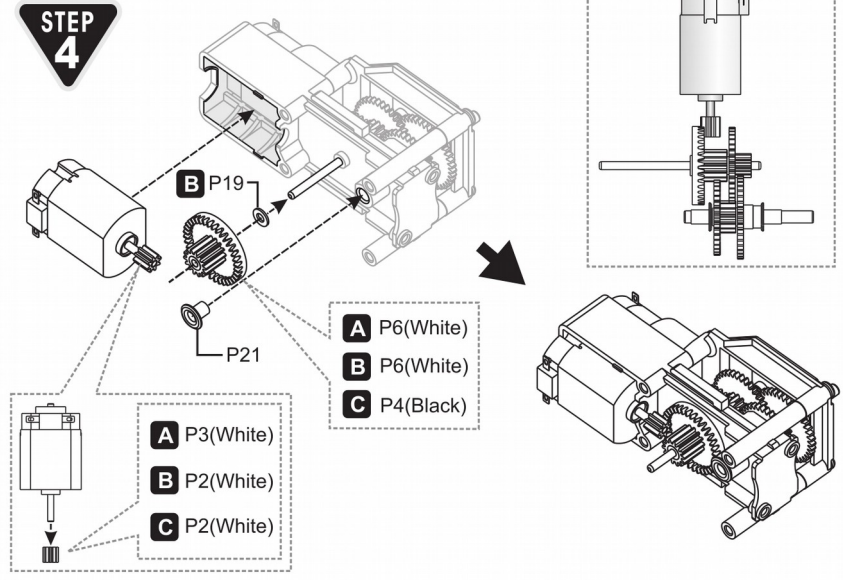

STEP 5

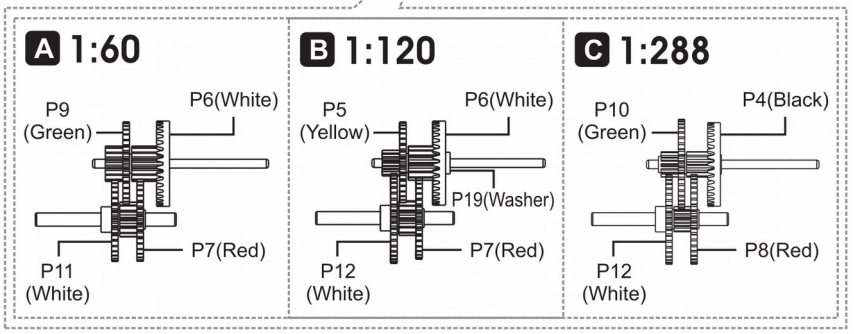
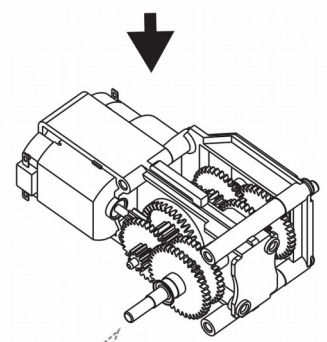
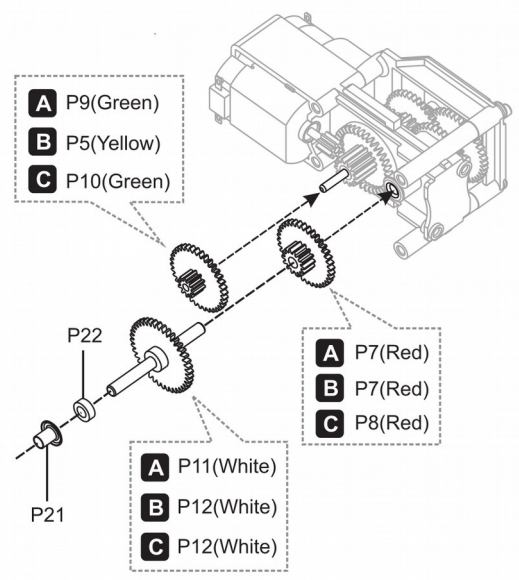

**STEP
6**

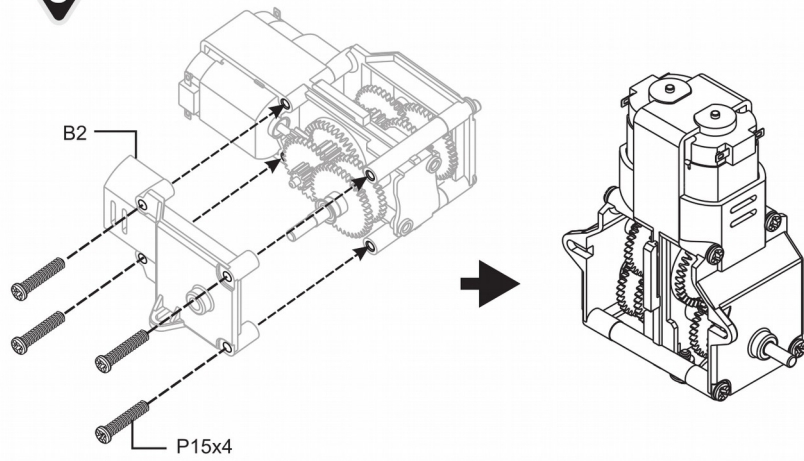

Application

1

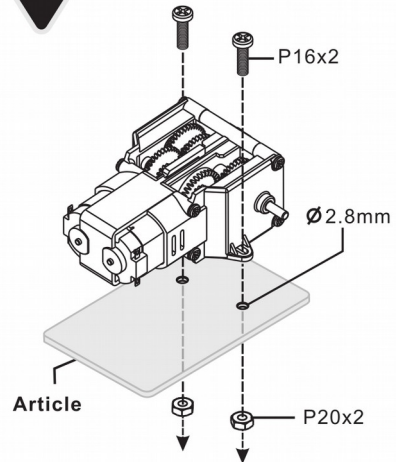

2

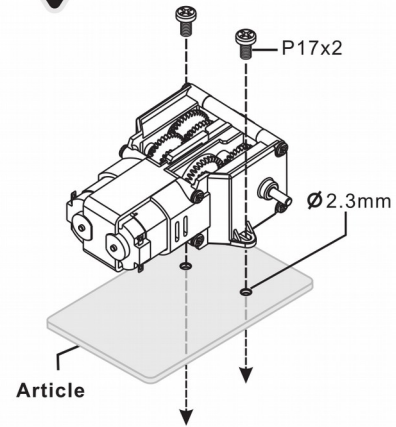

3

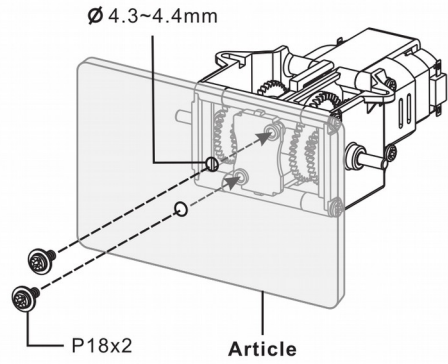

4

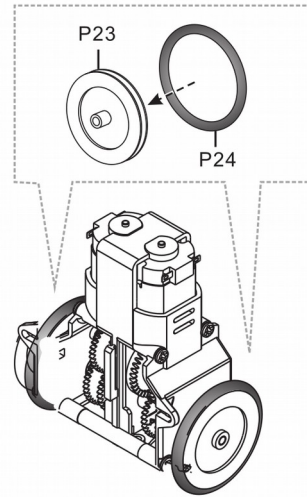

5-1

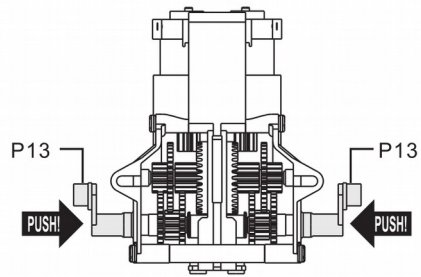

5-2

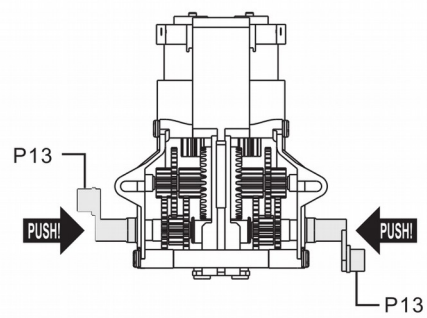

Use this device with original accessories only. Velleman nv cannot be held responsible in the event of damage or injury resulting from (incorrect) use of this device.

For more info concerning this product and the latest version of this manual, please visit our website www.velleman.eu.

The information in this manual is subject to change without prior notice.

© COPYRIGHT NOTICE

The copyright to this manual is owned by Velleman nv. All worldwide rights reserved. No part of this manual may be copied, reproduced, translated or reduced to any electronic medium or otherwise without the prior written consent of the copyright holder.



To all residents of the European Union
Important environmental information about this product
This symbol on the device or the package indicates that disposal of the device after its lifecycle could harm the environment. Do not dispose of the unit (or batteries) as unsorted municipal waste; it should be taken to a specialized company for recycling.

This device should be returned to your distributor or to a local recycling service. Respect the local environmental rules.

If in doubt, contact your local waste disposal authorities.

Thank you for choosing Velleman! Please read the manual thoroughly before bringing this device into service. If the device was damaged in transit, don't install or use it and contact your dealer.