

**PRIORITY TESTING GAME**  
CODE 137 **LEVEL 1**

This circuit is the electronic circuit applied for decision making e.g. games as seen on TV which the first player who presses the switch has the right to answer. The light will shown at only that player stage ever other players press the switch afterward, This circuit is applied for only 2 to 3 players only.

**Technical specifications:**

- power supply: 9-12VDC.
- consumption: 10mA max.
- each LED indication who press the switch to the first time.
- PCB dimensions : 2.36 x 1.68 inch.

**How to works:**

Switch S1, S2 and S3 are the switch for the 3 players. If the first player press the switch, the current ill transfer from R1 through D1 to the base of TR1 and makes TR1 works, the collector of TR1 is shorted and transfers voltage to ground. LED1 will light on while LED2 and LED3 are light off when pressing the switch S1. Because if S2 and S3 are pressed, the current will transfer form R2, R3, D4 and D8 through the collector of TR1 shorts to ground. There is no the current transfer to the base of TR2 and TR3 ,cause TR2 and TR3 doesn't work, LED2 and LED3 are no display. If S2 is pressed firstly, voltage will transfer from R3 and D6 to the base of R2 and shorted to ground, cause LED2 is light on while LED1 and LED3 are light off. Because the voltage at the base of TR1 and TR3 is shorted to ground through D3 and D5 respectively. There is on way that all LED will startpromply at the same time except the circuit is damaged.

**PCB assembly:**

Shown in Figure 3 is the assembled PCB. Starting with the lowest height components first, taking care not to short any tracks or touch the edge connector with solder. Some tracks run under components, and care should be taken not to short out these tracks. All components with axial leads should be carefully bent to fit the position on the PCB and then soldered into place. Make sure that the electrolytic capacitors are inserted the correct way

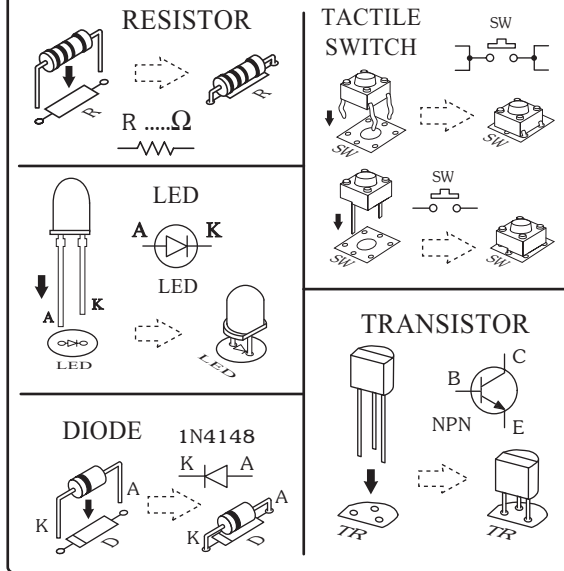
around. The LED has a flat spot on the body which lines up with the line on the overlay. Now check that you really did mount them all the right way round!

**Testing:**

Connect the power supply 9 to 12V to circuit. With the positive pole is connected to "+9V" point and the negative pole is connected to "G" point. ALL LED don't light on yet.

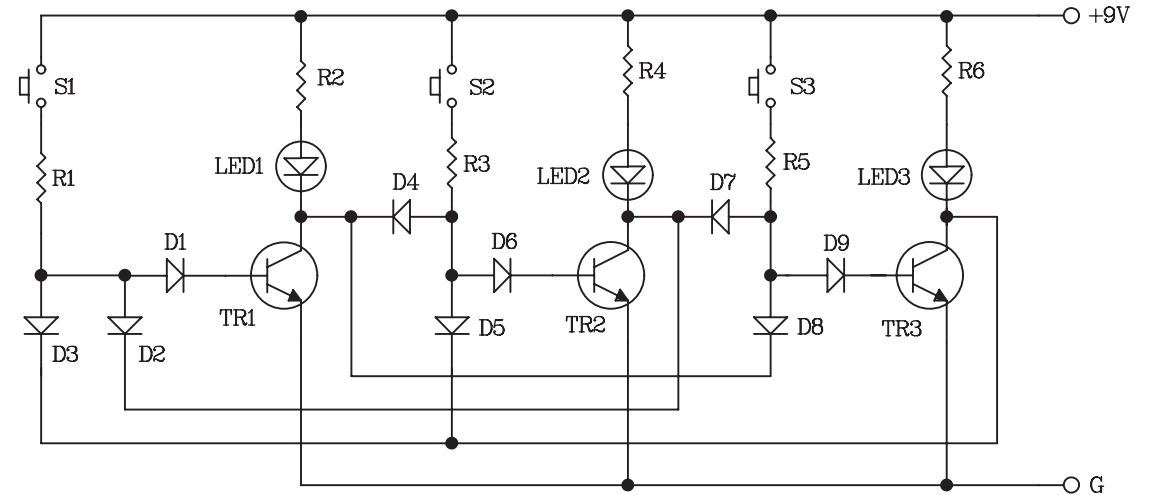
- 1.Pressing S1, LED1 is light on.
- 2.Pressing S2, LED2 is light on.
- 3.Pressing S3, LED3 is light on.
- 4.Press and hold S1, LED1 will light on. Pressing S2, LED2 is no display and pressing S3, LED3 is no display.
- 5.Press and hold S2, LED2 will light on. Pressing S1, LED1 is no display and pressing S3, LED3 is no display.
- 6.Press and hold S3, LED3 will light on. Pressing S1, LED1 is no display and pressing S2, LED2 is no display.

**Figure 1. Installing the componants**

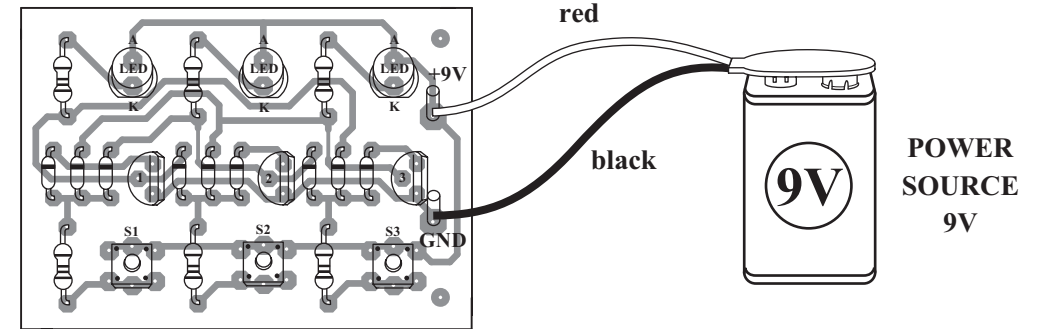


**Troubleshooting:**

The most problem like the fault soldering. Check all the soldering joint suspicious. If you discover the short track or the short soldering joint, re-solder at that point and check other the soldering joint. Check the position of all component on the PCB. See that there are no components missing or inserted in the wrong places. Make sure that all the polarised components have been soldered the right way round.

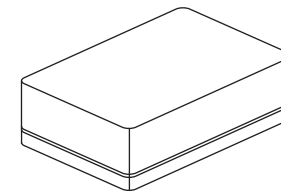


**Figure 2. The priority testing game circuit**



**FK137-1**

**Figure 3. Connections**



**NOTE:**

**FUTURE BOX FB03 is suitable for this kit.**

NEW KIT SET **NEW**

CODE FK	DESCRIPTION	POWER
271	LIGHT ACTIVATE ALARM (COCK VOICE) WITH SPEAKER	3VDC
272	SPACE GUN 3 TONE WITH SPEAKER	9VDC