

DVR81xx Series Image Recording Module

Users Guide

- 1. Brief Spec**
- 2. Application Note**
- 3. EMC plot**

DVR81xx Series Image Recording Module

Description

This image recording module is a standard module which can be designed for various application by firmware change. We will provide some standard firmware but also help customer making his own application.

Features

- ✓ Small in size: 80x55mm
- ✓ On board Flash memory (option)
- ✓ On board SD card (option)
- ✓ DC12V operation
- ✓ Allow 2 video channels input
- ✓ Video output to TV
- ✓ Trigger input – active low
- ✓ Alarm output – active low
- ✓ Keyboard input – 4 bits with common ground
- ✓ Preset NTSC or PAL TV system input
- ✓ Preset JPG/AVI for simple operation
- ✓ 2mm pin connectors

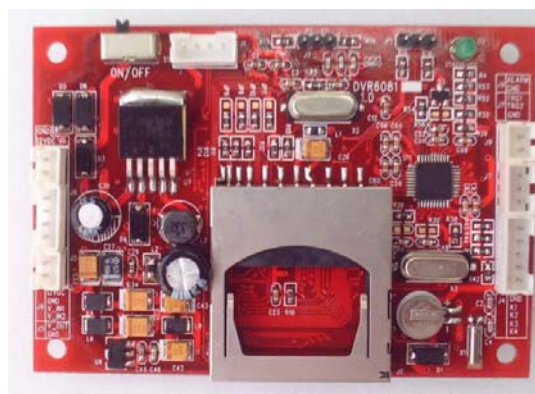

Connector Description

Note: the connectors shown below will depend on the firmware design, not applicable for all models.

Connector	Function	Remark
JP1	Select NTSC/PAL	Need to be selected before power up
J1	NC	For debug purpose,
J2	SD card slot	Support up to 2G SD card
J3	Select JPG/AVI	Need to be selected before power up
J4	Keyboard input	4 bit binary input
J5	Video out	2-pins, To output video signal to TV set
J6	Camera input	4-pins, for 2 ch video and power supply
J7	Trigger input	3-pins, for 2 trigger input, active low
J8	DC output or aux input	2-pins, for DC12V output to camera or aux power input
J9	Alarm output	2-pins, for alarm output, active low

Application Examples

The following examples are ready to production, detail spec and operation please refer to the relevant document

Model No	Application	Description
8100	General Purpose	Full function, 4 bit key input, with motion detect
8101	Door Phone	Single channel, single folder
8102	Taxi Cam	Single channel, 2-key operation
8103	Vehicle Black Box	2-ch switching, auto capture, 3sec/frame
8104	Embedded to alarm system	Full function with serial communication to command
8105	Video recording only	Slow recording frame rate, VGA format, playback like VCR

Electrical Characteristics (at room temperature 25C)

Parameter	Condition	Min	Type	Max	Unit
Operation Voltage		7.5	12	13.5	V
Operation Current		238	145	128	mA
Standby Current	No Video o/p	215	130	120	mA
Alarm Output current	At 3V	-	-	40	mA
Trigger Input Voltage		0	-	0.9	V

DVR81xx Series Application Note

Scope: This document is trying to provide more information on the modules such that users can apply it for various application without damaging the module.

1. Block Diagram

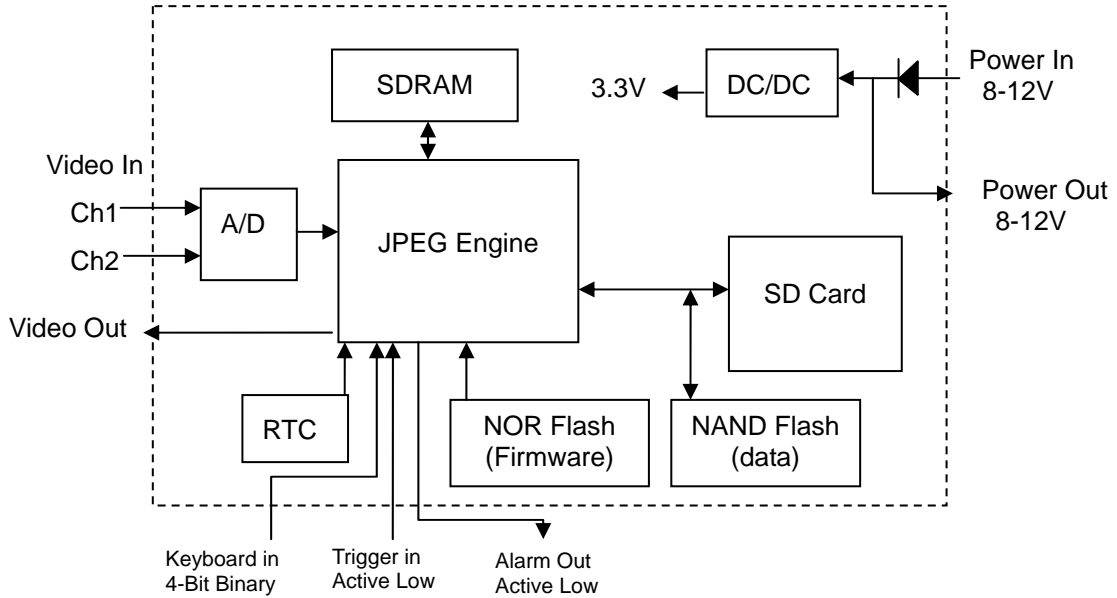

2. Power

2.1 This module accepts 8-12V DC input. DC/DC converter is used to step down the supply to 3.3V for system. Power consumption of the module will depend on the configuration of external device connect to.

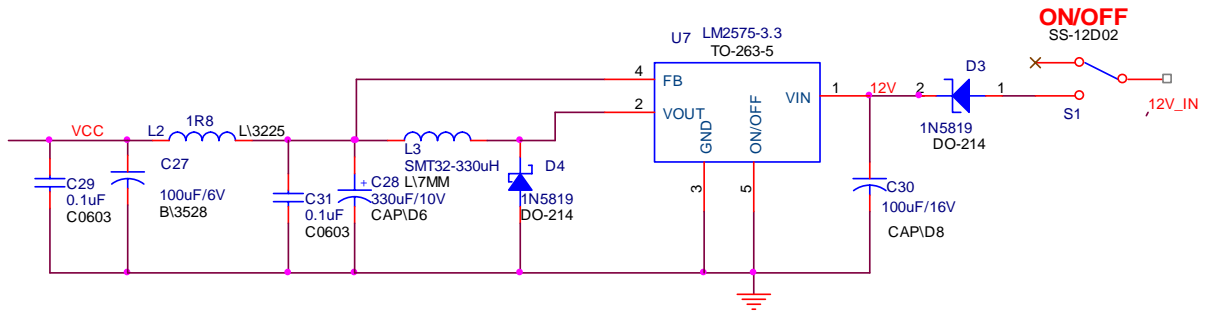

2.2 Power input connect to J6 pin 4, it is polarity protected.

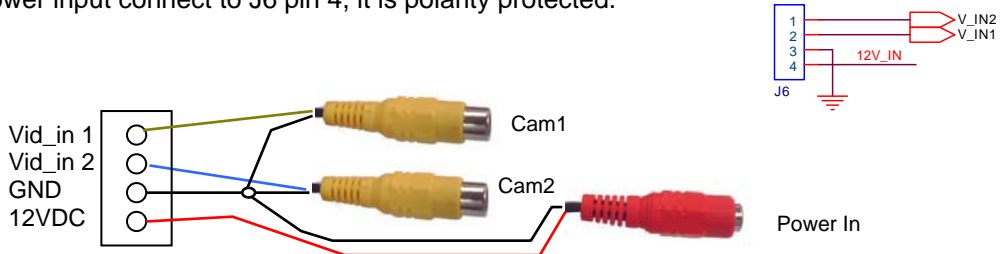

2.3 J8 can be used to output DC power to external cameras or as aux power input (non polarity protected). Below is the connection example

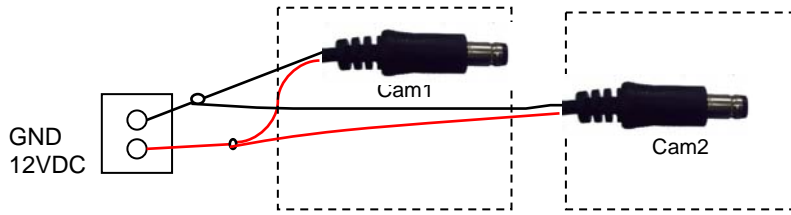

2.4 If DC power output is not required, leave J8. User can use J8 for aux power input, if he doesn't use J6 pin 4. But need to take care the polarity of power plug is correct. Connection example is shown as below.

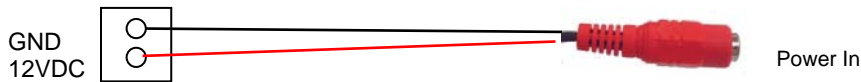

3. On board Hardware settings

3.1 There are 2 hardware setting for power up detect, J3 is file format, and JP1 is TV system. Use short bar to short the 2 pos, center and edge. There is a pull high and pull low resistor for the selection. If no short bar existed, it will be set to default value

3.2 J3, to select JPG or AVI, default is JPEG

3.3 JP1 to select TV system, default is PAL

3.4 If the hardware settings are override by menu setting, they will be reset after power up.

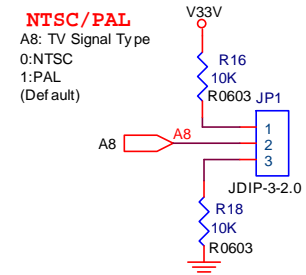
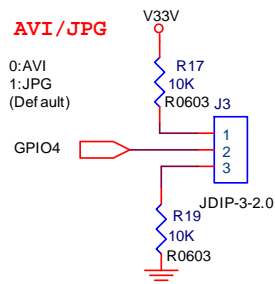

4. I/Os and its external connection

4.1 There are 3 sets of I/O to connect external devices: keyboard, trigger input and alarm output

4.2 Keyboard J4: it is a 4-bit binary keyboard, user can make his own keyboard according to the following schematic. Port J4 is internal pull high.

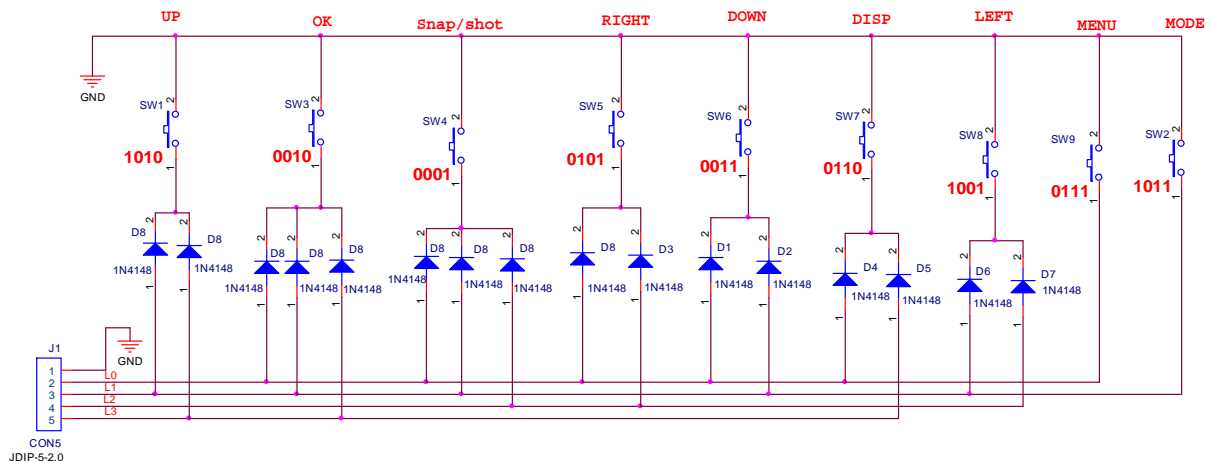

- 4.3 Trigger input J7: there are 2 GPIO to accept trigger input of active low. It can be a simple tact switch to short the trigger pin to ground to provide a low signal to the module. They are internal pull high
- 4.4 Alarm output J9: it is internal pull high, for some firmware, it will provide a low signal to trigger external devices, such as burger alarm, auto dialer, RF transmitter and etc.

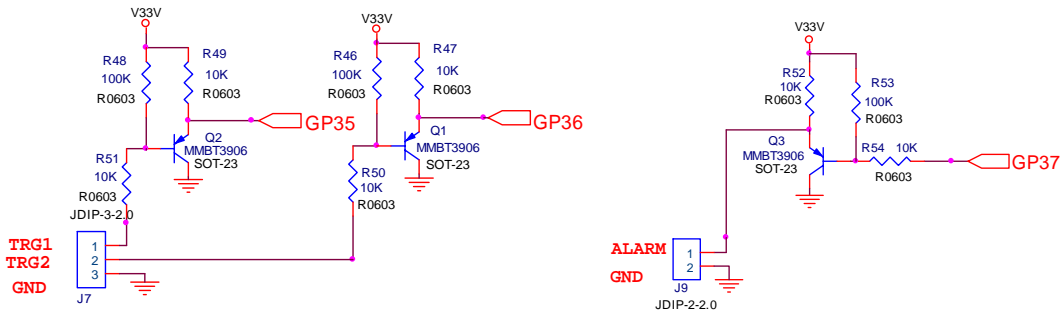

5. Application example
 5.1 When using wired camera

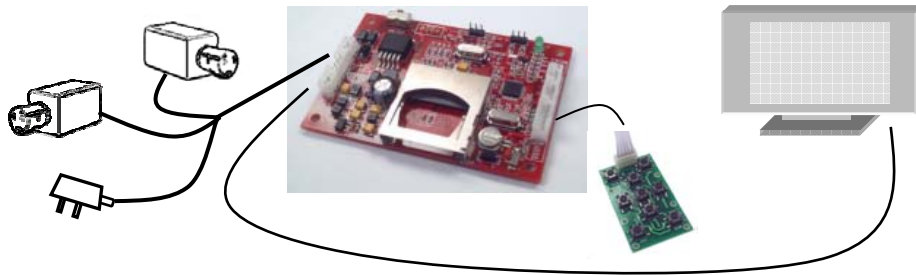

5.2 When using RF camera system
 In this case, it can support up to 4 channels RF camera as the receiver does, but only one channel to input the DVR module at a time. On the other hand, it is not recommend to use motion detect in this system. The reason is that it will be false triggered by the noise or interrupt of RF signal which is always happened in the RF camera system.

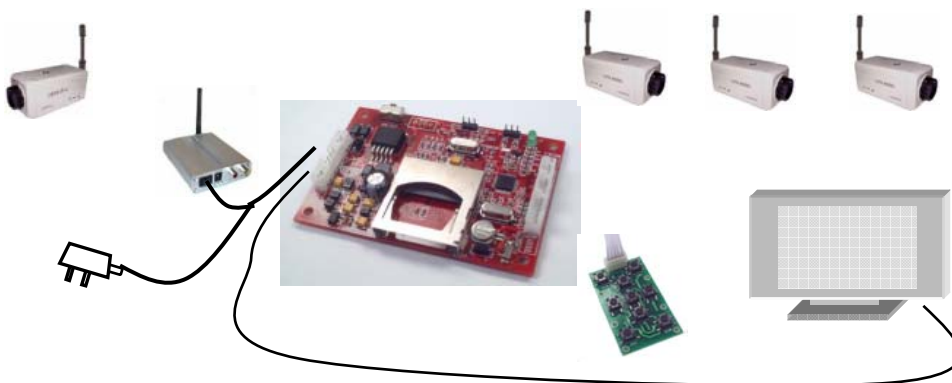

DVR8100 EMC Plot

The module has been passed the EMC requirement of EN55022.

File# : COMEDIA
 Site : 3M CHAMBER
 Limit : EN55022B
 EUT : M/N:DVR60810
 Power : AC 230V/50Hz
 Note : ON

Time : 2006/12/16 - 16:34
 Probe : VULB9163 - HORIZONTAL
 Margin : 6
 Std : 30
 Trace :

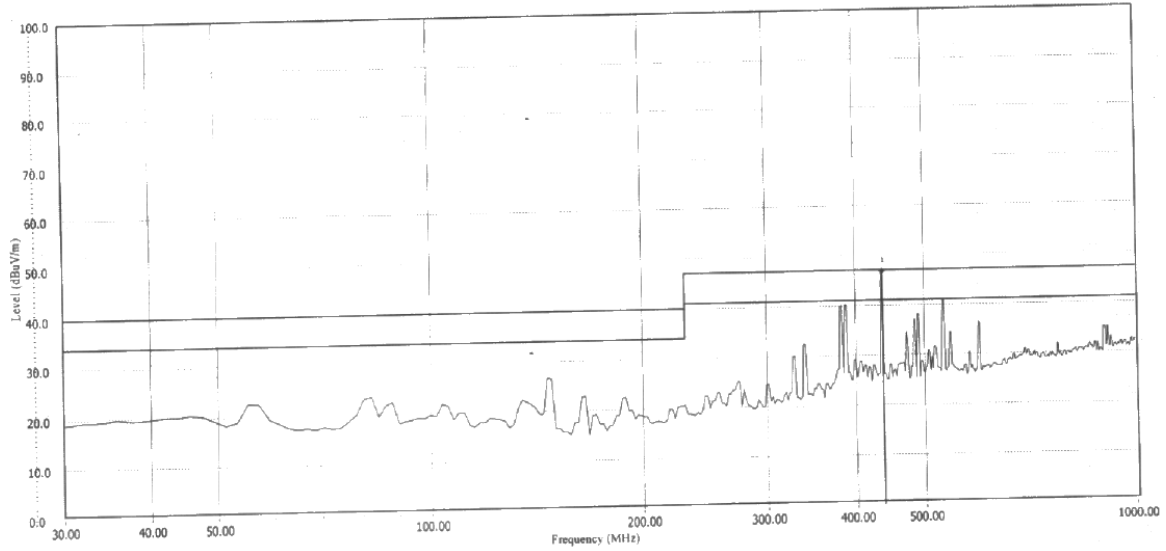

Flag	Mark	Freq (MHz)	Measure Level (dB)	Reading Level (dBuV)	Over Limit (dBuV/m)	Limit (dBuV/m)	Probe Factor (dB/m)	Cable Loss (dB)	Amp Factor (dB)	Ant Pos (cm)	Table Pos (deg)	Type
1	!	*	437.400	46.710	28.000	-0.290	47.000	17.710	1.000	0.000	0.000	0.000