

### Power Input/ Daisy-Chain Output

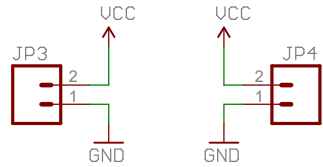

Expecting 5VDC power.  
Current consumed is dependent  
on servo type and loading.

### ISP Connection

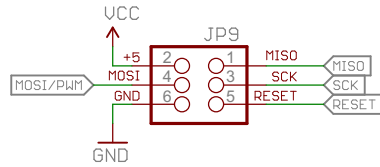

### Button Connection

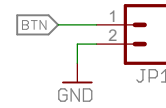

Pulled up internally in processor  
Datasheet says R<sub>up</sub> is in the 20K to 50K range.

### Servo Motor Output

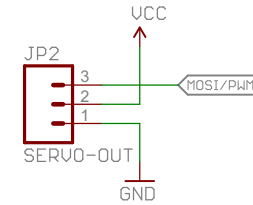

### Microcontroller

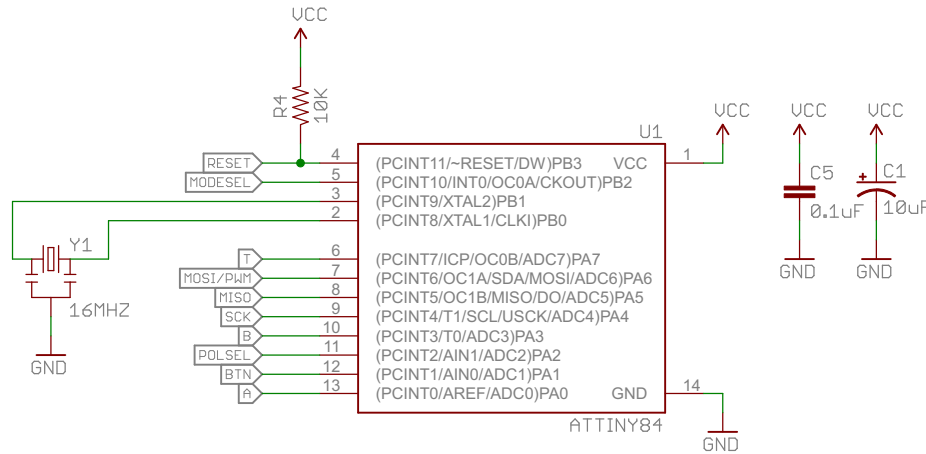

### Control Potentiometers

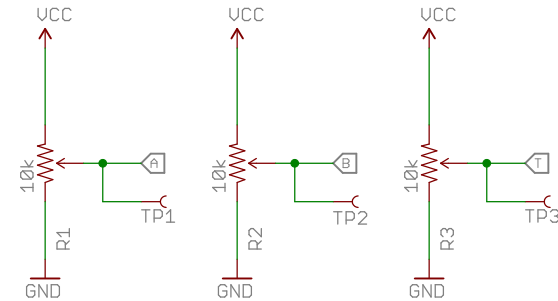

These pots control the servo position and timing.

"A" sets the default position if the servo.  
"B" sets the position it travels to when the switch  
is actuated (whether it stays there or not is  
configured with the mode jumper).  
"T" sets the time it takes to move from A to B  
and back, over a range of 0 to 10 seconds.

### Mode Configuration

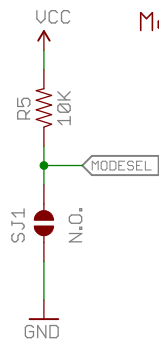

SJ1 sets mode  
-Open, default, is bistable mode. While input is de-asserted, servo sits at A. While input is asserted, it goes to B returning to A when input is deasserted. If servo travel takes longer then the input is held, cycle will be incomplete.

-Closed is one-shot mode.  
When input trips, servo will cycle from A to B, then return to A. It will always do the full cycle.

### Polarity Configuration

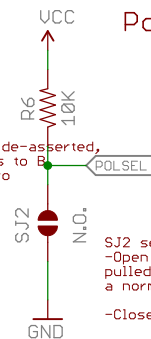

SJ2 sets input polarity  
-Open (default) is active low, with switch input pulled up internally. Intended for use with a normally-open switch or active-low logic.

-Closed is for active high-logic.



Released under the Creative Commons  
Attribution Share-Alike 4.0 License  
<https://creativecommons.org/licenses/by-sa/4.0/>

TITLE: SparkFun\_Servo\_Trigger\_v10a

Design by:  
Byron Jacquot

REV:  
V10

Date: 7/7/2015 3:57:12 PM

Sheet: 1/1