

Kit 88. 10 + 10 Watt Stereo Amplifier

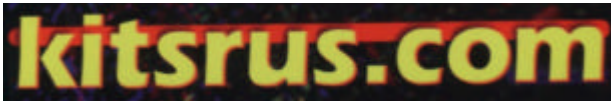

Kit 88 is a class AB stereo audio power amplifier designed for quality hi-fi applications using a TDA2009A module. It is easy to construct and has a minimum of external components. The module has output current protection and thermal protection. This is the data book circuit which gives an excellent sound. The supply voltage required for this kit is 8 - 24V DC at 1 to 2 Amps. Maximum output power will only be obtained with a power supply of at least 20V and greater than 1.5 A, and using 4 ohm speakers.

The power supply should be well filtered to reduce mains hum, the on board capacitors alone are not adequate for this purpose but are necessary to ensure stability. Extra filtering is unnecessary if operating from a battery.

Construction.

Follow the printed circuit overlay with reference to the circuit diagram where necessary. Add the lowest height components to the board first, starting with the resistors. Be careful to get the electrolytic capacitors in the correct way around and all parts in their correct positions. Be careful when soldering the IC not to use excessive heat. Use some heat sink compound between the heat sink & the IC. Also note if you intend to drive it very hard, it will require a bigger heatsink. Use shielded signal wire for the input connections, and at least 16/0.2 hook up wire for DC input and speaker outputs. Try to keep lead lengths as short as possible

Operation.

The circuit is very straight forward. Most of the circuitry is contained within the amplifier module. C1 & C2 are input coupling capacitors and block DC, as do C10 & C11 which are the output coupling capacitors, and C6 & C7 which block DC from the feed back loop. R1/R2 (and R3/R4) set the level of feed back.

The gain is equal to $1 + (R1/R2) = 68$ or 37 dB. C8/R5 (and C9/R6) provide a high frequency load for stability where loudspeaker inductive reactance may become excessive. C4 and C5 provide power supply decoupling or filtering.

The absolute maximum supply voltage for this Kit is 28V. Check the power supply voltage and polarity before connecting to the board. We found no trouble in getting this kit to work. If yours does not work, first check all external wiring, make sure there are no shorts, then check all the component positions and orientation. Also check all solder joints and make sure there are no solder bridges.

Specifications :

| | |
|----------------------|---|
| D.C. Input : | 8 – 24V at 1 – 2 A |
| Power output : | > 10W RMS /channel, 4 ohm load, 24V DC supply. > 6W RMS /channel 8 ohm load 24V DC supply. > 4W RMS /channel, 4 ohm load 12V DC supply. |
| S/N ratio : | > 75 dBA re. 10W output. |
| Frequency response : | ~ 10 Hz to 50 kHz –3 dB |
| Gain : | ~ 36 dB |
| Input level : | ~ 100 mV for full output |

You may download the full data sheet for the TDA2009A from my website :

[http:// kitsrus.com](http://kitsrus.com)

or from ST Microelectronics at : **www.st.com**

Kit 88. 10 + 10 Watt Stereo Amplifier

Circuit Diagram

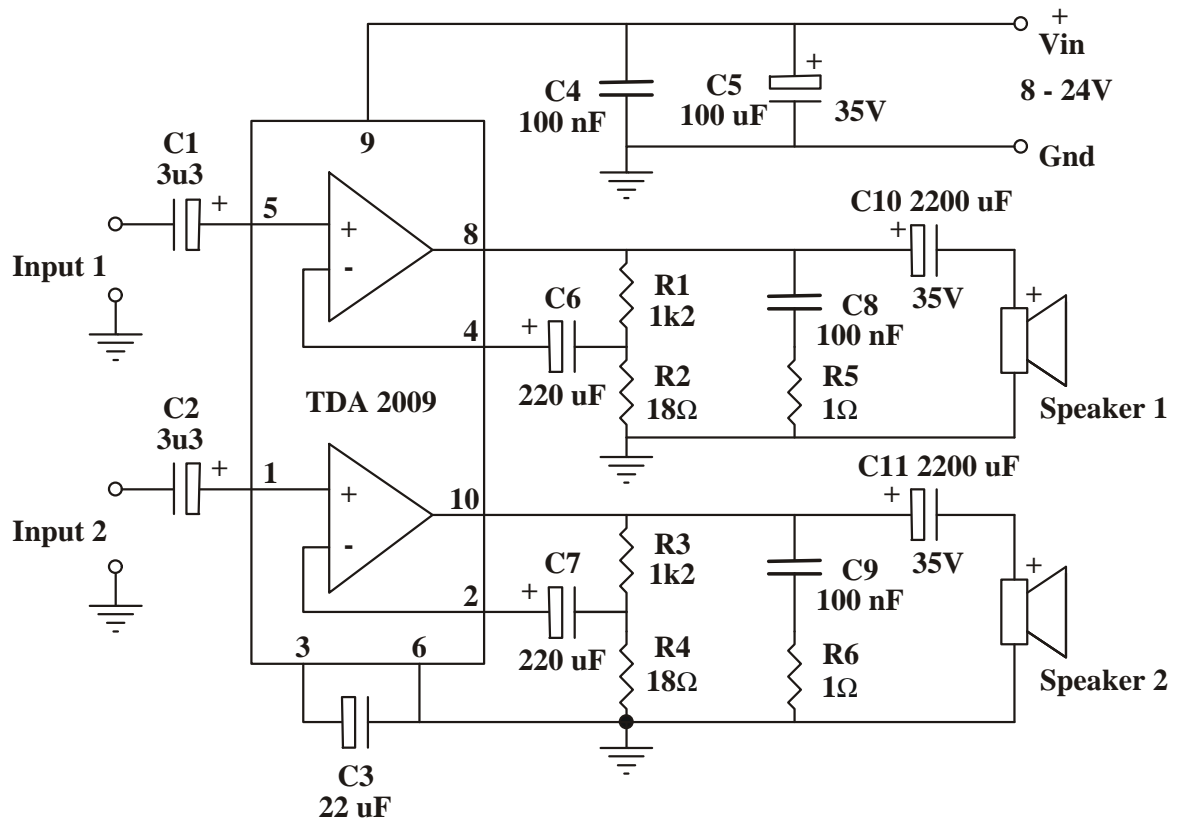

Components

Resistors : 1/2W, 5%.

| | | |
|----------------------|-------|---|
| 1K2 brown red red | R1 R3 | 2 |
| 1R brown black gold | R5 R6 | 2 |
| 18R brown grey black | R2 R4 | 2 |

Capacitors :

| | | |
|-----------------|----------|---|
| 3u3 50V mini | C1 C2 | 2 |
| 22uF 16V | C3 | 1 |
| 100uF 35V | C5 | 1 |
| 220uF 10V | C6 C7 | 2 |
| 2200uF 35V | C10 C11 | 2 |
| 100nF 104 mylar | C4 C8 C9 | 3 |

| | |
|---------------------------|---|
| TDA2009A amp module | 1 |
| Heat sink HS215 or HS110 | 1 |
| Nut & bolt set for HS | 1 |
| 2 pole terminal block | 1 |
| 3 pole terminal block | 2 |
| K88 Printed Circuit Board | 1 |

Kit 88. 10 + 10 Watt Stereo Amplifier

**Distortion @ 9W RMS Output
1 kHz input and 24V DC
supply:**

