

# FN-RM01 MP3 Audio Recorder and Player Module

## Datasheet

### V1.1

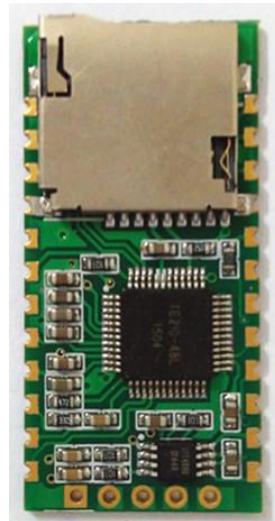

## Contents

<b>1. Overviews</b> .....	<b>2</b>
1.1. Brief Introduction.....	2
1.2. Product Features.....	2
1.3. Technical Parameters.....	2
<b>2. Pin Configuration</b> .....	<b>3</b>
<b>3. ADKEY Control Mode</b> .....	<b>4</b>
<b>4. Serial Control Mode</b> .....	<b>5</b>
4.1. Serial Communication Protocol.....	5
4.2. Serial Commands.....	5
4.3. Detailed Annotation of Control Commands.....	7
4.4. Detailed Annotation of Query Commands.....	15
<b>5. Application Circuits</b> .....	<b>18</b>
<b>6. GPIO Features</b> .....	<b>19</b>
<b>7. PCB Size</b> .....	<b>20</b>



## 1. Overviews

### 1.1. Brief Introduction

FN-RM01 is a high-quality MP3 audio recorder and player module, designed and launched by Flyron Technology Co., Ltd. Flexible audio recording modes including MIC recording, Line-in recording and stereo 2-channel Aux-in recording, optional audio recording bit rates, multiple formats of audio files playback supported including MP3, WAV and WMA, and as well as simple communication control modes are the main advantages of this module, which can meet kinds of needs from customers.

### 1.2. Product Features

1. Supports microphone(mono), line-in(mono), and Aux-in(stereo) audio recording modes.
2. Supports AD keys control mode(play/pause, next, previous, record, and stop).
3. Supports standard UART serial communication control mode.
4. Supports playback of MP3, WAV, and WMA formats audio files, with great sound quality.
5. Supports up to 48Khz sampling rate and 128Kbps bit rate of high-quality MP3 audio recording.
6. Supports USB sound card mode.
7. Use micro SD card and USB flash drive as the storage devices; supports max 32GB micro SD card and 32GB USB flash drive.
8. Supports FAT or FAT32 file systems.
9. Can freely replace sound files in the micro SD card via USB port.
10. Built-in 1W amplifier that can direct drive 8Ω / 1W speaker.
11. 32 levels adjustable sound volume.
12. DC 5V power supply.

### 1.3. Technical Parameters

Item	Description
Audio Formats Supported at Playback Status	MP3: Supports 8K-48KHZ, 8-320Kbps WAV: 8K-44.1KHZ WMA: 8K-44.1KHZ
USB Port	USB2.0
Working Voltage	DC3.3-5V
Rated Current	20-250MA(with load)
Voltage of IO Port	3.3V TTL level
Dimensions	37*18*2.7mm
Operating Temp.	-40-85℃
Humidity	5%-95%

## 2. Pin Configuration

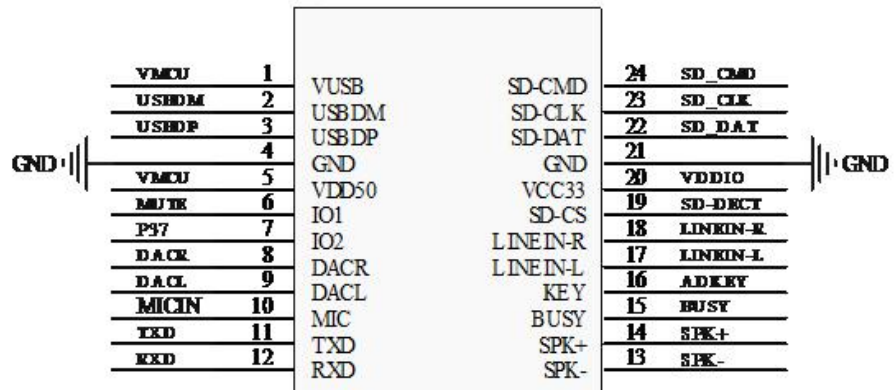
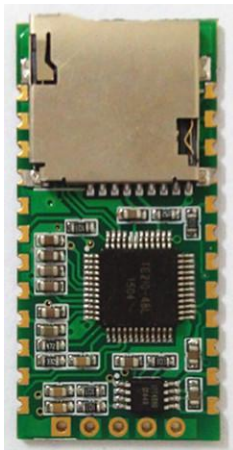

No.	Name	Attribute	Description	Notes
1	VUSB	PWR	Power supply for USB	DC 5V
2	USBDM	DM	USB communication DM port	
3	USBDP	DP	USB communication DP port	
4	GND	IO	Ground	
5	VDD50	IO	Power supply for audio IC	DC 5V
6	IO1	IO	Used for MUTE control	
7	IO2	IO	N/A(reserved)	
8	DACR	ANA	DACR audio output	Connect with an external amplifier
9	DACL	ANA	DACL audio output	
10	MIC	AD	MIC voice recording control port	
11	TXD	IO	UART serial output	
12	RXD	IO	UART serial input	
13	SPI-	ANA	PWM audio output	Directly drive 8ohm 1W speaker
14	SPK+	ANA	PWM audio output	
15	BUSY	IO	Busy indication	Low level: playing and recording High level: standby
16	ADKEY	IO	AD KEY control	
17	LINEIN_L	AD	LINE IN recording left channel	
18	LINEIN_R	AD	LINE IN recording right channel	
19	SD-CS	IO	CS port for communication with SD	

20	VCC33	PWR	DC 3.3V output	Supply 3.3V power
21	GND	GND	Ground	
22	SD-DAT	IO	DATA port for communication with SD	
23	SD_CLK	IO	CLK port for communication with SD	
24	SD_CMD	IO	CMD port for communication with SD	

### 3. AD Key Control Mode

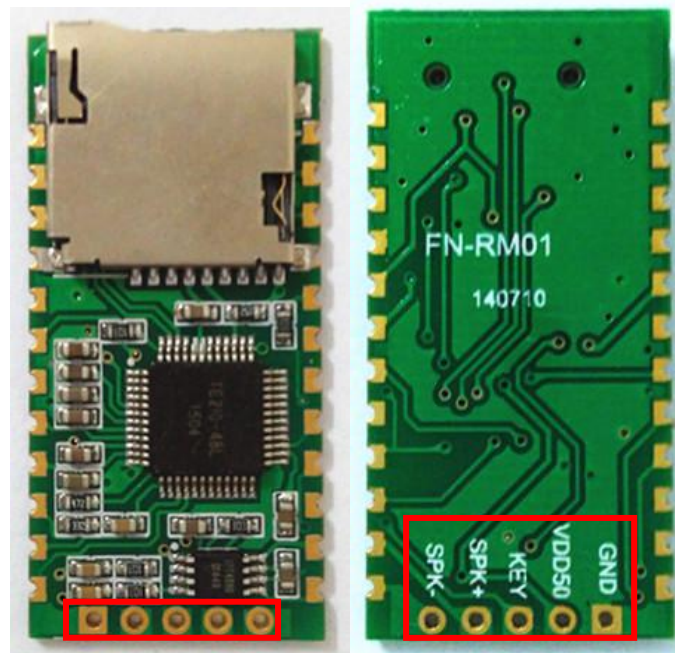

In order to connect to external buttons easily based on AD key control for users to accomplish button control, we made the solder pads at the bottom of the module as shown above marked with the red box. Through AD key function(the pinout “KEY”) and connecting with specific values of resistors, users can lead out 5 different functional key control as below. Please refer to the application circuit 5.1 for the connection in details of this part.

Key	Operation	Function
Play/Pause	Short press	Play/Pause
Next	Short press	For next sound
Previous	Short press	For previous sound
Stop	Short press	Stop playback
Record	Short press	Short press to start recording and short press again to stop recording

**Note: ADKEY function can be customized according to customer's special requirements.**

## 4. Serial Control Mode

### 4.1. Serial Communication Protocol

FN-RM01 supports standard UART asynchronous serial control(communication baud rate is 9600bps), working at 3.3V TTL level. Possible to be converted to RS232 level via MAX3232 chip. The communication protocol format is as below.

**Start code: 0x7E**

**Number: number of bytes from Number itself to check code**

**Command: a specific serial command byte**

**Parameter: to realize a specific function with a command byte together**

**Check code: it's a sum value of Number+Command+Parameter(it uses one byte only that is from the lower 8 bits)**

**End code: 0x7E**

If use a serial assistant, you need to set the parameters correctly as below.



**Note: All of the commands need to be sent in hex.**

## 4.2. Serial Commands

### 4.2.1. Control Commands

Command	Function Description	Note
0xA2	Specify playback(of a file) by indexed sequence in the root directory of the storage device	See 4.3.1
0xA3	Specify playback(of a file) by file name in the root directory of the storage device	See 4.3.2

0xA4	Specify playback(of a file) by indexed sequence in a folder	See 4.3.3
0xA5	Specify playback(of a file) by file name in a folder	See 4.3.4
0xAA	Pause playback	See 4.3.5
0xAB	Stop playback	See 4.3.6
0xAC	Next	See 4.3.7
0xAD	Previous	See 4.3.8
0xAE	Volume control	See 4.3.9
0xAF	Specify a playback mode	See 4.3.10
0xD0	Fast forward	See 4.3.11
0xD1	Fast backward	See 4.3.12
0xD2	Choose a storage device(SD card or USB flash drive) to work with the module	See 4.3.13
0xD3	Choose audio-recording input mode	See 4.3.14
0xD4	Set audio-recording quality(bit rate)	See 4.3.15
0xD5	Specify recording(of a file)by indexed sequence in the root directory of the storage device	See 4.3.16
0xD6	Specify recording(of a file)by file name in the root directory of the storage device	See 4.3.17
0xD7	Specify recording(of a file) by indexed sequence in a folder	See 4.3.18
0xD8	Specify recording(of a file) by file name in a folder	See 4.3.19
0xD9	Stop recording	See 4.3.20
0xDA	Delete a specified file in the storage device by indexed sequence	See 4.3.21
0xDB	Delete a specified file in the storage device by file name	See 4.3.22
0xDC	Delete a specified file in a folder by indexed sequence	See 4.3.23
0xDD	Delete a specified file in a folder by file name	See 4.3.24
0xDE	Delete all of the files	See 4.3.25&4.3.26

#### 4.2.2 Query Commands

Command	Function Description	Note
---------	----------------------	------

0xC1	Query current volume level	See 4.4.1
0xC2	Query current work status	See 4.4.2
0xC5	Query the total file numbers in the root directory	See 4.4.3
0xC6	Query the total file numbers in the specified folder in the storage device	See 4.4.4
0xC9	Query current sound file being played	See 4.4.5
0xCA	Query current connection status regarding SD card and USB flash drive	See 4.4.6
0xCB	Query whether a sound file is in the root directory of a storage device	See 4.4.7
0xCC	Query whether a sound file is in a folder	See 4.4.8
0xCD	Query the name of the sound file currently playing	See 4.4.9
0xCE	Query space left in the storage device	See 4.4.10

### 4.3. Detailed Annotation of Control Commands

#### 4.3.1. Specify playback(of a file) by indexed sequence in the root directory of the storage device

Start Code	Number	Command	MSB of the Sound File	LSB of the Sound File	Check Code	End Code
7E	05	A2	00	01	A8	7E

This command is to play the 1<sup>st</sup> sound file in the root directory of the storage device. Please note the sound files here are ranked according to physical indexed sequence.

Returned data: 00 represents command is executed successfully; 01 represents no this file.

**Note: If the specified sound file doesn't exist, the module will not work.**

#### 4.3.2. Specify playback(of a file) by file name in the root directory of the storage device

Start Code	Number	Command	File Name(from MSB to LSB)				Check Code	End Code
7E	07	A3	54(T)	30(0)	30 (0)	32(2)	90	7E

This command is to play a sound file by file name in the root of the storage device. The file name here(T002) uses ASCII code to indicate. The hex codes 54, 30, 30, and 32 correspond to the characters T002 respectively, so it means the sound file named T002.mp3 is going to be played back in the root of the storage device.

Returned data: 00 represents the command is executed successfully; 01 represents no this file.

**Note: When rename a sound file, it can't be more than 8 characters.**

**4.3.3. Specify playback(of a file) by indexed sequence in a folder**

Start Code	Number	Command	Folder Name(from MSB to LSB)					File Index(from MSB to LSB)		Check Code	End Code
7E	0A	A4	4D (M)	55 (U)	53 (S)	49 (I)	43 (C)	00	01	30	7E

This command is to play a sound file by indexed sequence in a folder. Here the folder name(MUSIC) uses ASCII code to indicate. The hex codes 4D, 55, 53, 49 and 43 respectively correspond to the characters MUSIC, so it means the 1<sup>st</sup> sound file(or 0001.mp3) in the folder named MUSIC is going to be played back.

Returned data: 00 represents the command is executed successfully; 01 represents no this file.

**Note: When rename a folder, it must be 5 characters.**

**4.3.4. Specify playback(of a file) by file name in a folder**

Start Code	Number	Command	Folder Name(from MSB to LSB)					File Name(from MSB to LSB)				Check Code	End Code
7E	0C	A5	4D (M)	55 (U)	53 (S)	49 (I)	43 (C)	54 (T)	30 (0)	30 (0)	32 (2)	18	7E

This command is to play a file by file name in a folder. Here the folder name(MUSIC) and the file name(T002) use ASCII code to indicate. The hex codes 4D, 55, 53 and 49 respectively correspond to the characters MUSIC, and the hex codes 54, 30, 30 and 32 respectively correspond to the characters T002, so it means the sound file named T002.mp3 in the folder named MUSIC is going to be played back.

Returned data: 00 represents the command is executed successfully; 01 represents no this file.

**Note: When rename a folder, it must be 5 characters, and when rename a sound file, it can't be more than 8 characters.**

**4.3.5. Pause playback**

Start Code	Number	Command	Check Code	End Code
7E	03	AA	AD	7E

Note: When this command is sent out first time during playback, the sound is paused, and if this command is sent out again, the sound continues to be played.

Returned data: 00 represents command is executed successfully; 01 represents command execution failed;



#### 4.3.6. Stop playback

Start Code	Number	Command	Check Code	End Code
7E	03	AB	AE	7E

Returned data: 00 represents command is executed successfully; 01 represents command execution failed;

#### 4.3.7. Next

Start Code	Number	Command	Check Code	End Code
7E	03	AC	AF	7E

Note: This command is to play the next sound. During the last sound is being played, if this command is sent out, the module will play the first sound.

Returned data: 00 represents command is executed successfully; 01 represents command execution failed;

#### 4.3.8. Previous

Start Code	Number	Command	Check Code	End Code
7E	03	AD	B0	7E

This command is to play the previous sound. During the first sound is being played, if this command is sent out, the module will play the last sound.

Returned data: 00 represents command is executed successfully; 01 represents command execution failed;

#### 4.3.9. Volume control

Start Code	Number	Command	Volume Level	Check Code	End Code
7E	04	AE	1F	D1	7E

There are total of 32 volume levels, i.e. 00-31. Level 00 is mute while level 31 is the maximum volume(level 30 is the default volume). As the example above, it is to send the maximum volume level 31.

Returned data: 00 represents command is executed successfully; 01 represents command execution failed;

#### 4.3.10. Specify a playback mode

Start Code	Number	Command	Parameter	Check Code	End Code
7E	04	AF	00: Single non-repeat mode(by default)	B3	7E
			01: Single repeat(loop) mode	B4	

			02: All repeat(loop) mode	B5	
			03: Random mode	B6	
			04: All repeat(loop) mode in the folder	B7	

Once the playback mode is changed, it always keeps in the changed mode, but it will resume to the default mode when it gets reset or re-powered on.

Returned data: 00 represents command is executed successfully; 01 represents command execution failed;

#### 4.3.11. Fast forward

Start Code	Number	Command	Check Code	End Code
7E	03	D0	D3	7E

Sending this command for the first time is to execute fast forward, and sending it for the second time to end fast forward.

Returned data: 00 represents command is executed successfully; 01 represents command execution failed;

#### 4.3.12. Fast backward

Start Code	Number	Command	Check Code	End Code
7E	03	D1	D4	7E

Sending this command for the first time is to execute fast backward, and sending it for the second time to end fast backward.

Returned data: 00 represents command is executed successfully; 01 represents command execution failed;

#### 4.3.13. Choose a storage device(SD card or USB flash drive) to work with the module

Start Code	Number	Command	Parameter	Check Code	End Code
7E	04	D2	00: shift to SD card(by default)	D6	7E
			01: shift to USB flash drive	D7	

FN-RM01 supports SD card and USB flash drive as the storage devices. When the two storage devices exist in the same time, choosing one of both to work with the module is required. By default, SD card is the priority storage device. Whenever a shift is made, it would be better to send the query command to confirm if the shift is successful firstly(refer to 4.5.6).

Returned data: 00 represents command is executed successfully; 01 represents command execution failed or

the storage device unfound.

#### 4.3.14. Choose audio-recording input mode

Start Code	Number	Command	Parameter	Check Code	End Code
7E	04	D3	00: connect with MIC(signal P03) 10DB(default)	D7	7E
			01: connect with LINE-IN(signal P03) 3DB	D8	
			02: connect with 2-channel Aux-in(signal P02/P37) 3DB	D9	

It's possible for FN-RM01 to choose an audio-recording input mode among 3 of them as above. By default, the module works with MIC audio-recording input mode.

Returned data: 00 represents command is executed successfully; 01 represents command execution failed;

#### 4.3.15. Set audio-recording quality(bit rate)

Start Code	Number	Command	Parameter	Check Code	End Code
7E	04	D4	00: 128Kbps(by default)	D8	7E
			01: 96Kbps	D9	
			02: 64Kbps	DA	
			03: 32Kbps	DB	

It's possible for FN-RM01 to set audio-recording quality/choose audio-recording bit rate(code rate) as above.

By default, it is 128Kbps. The fixed sampling rate is 48KHz.

Returned data: 00 represents command is executed successfully; 01 represents command execution failed;

#### 4.3.16. Specify recording(of a file)by indexed sequence in the root directory of the storage device

Start Code	Number	Command	File Index(from MSB to LSB)		Check Code	End Code
7E	05	D5	00	02	DC	7E

This command is to record a file by indexed sequence in the root of the storage device. "00 02" represent the 2<sup>nd</sup> recording file that is going to be generated. If the 2<sup>nd</sup> recording file already exists(recorded previously), it will be covered directly with the new one.

Returned data: 00 represents command is executed successfully; 01 represents the storage device is full already; 02 represents command execution failed.

**Note: Here the default recording file name format is RExxx.mp3. As the example above, the recording file name is RE002.mp3. It supports to record maximum 999 files(RE001-RE999).**

**4.3.17. Specify recording(of a file)by file name in the root directory of the storage device**

Start Code	Number	Command	File Name(from MSB to LSB)				Check Code	End Code
7E	07	D6	54(T)	30(0)	30(0)	32(2)	C3	7E

This command is to record a file by file name in the root of the storage device. The file name(T002) uses ASCII code to indicate, and the hex codes 54, 30, 30, and 32 respectively correspond to the characters T002, it means the recording file named T002.mp3 is going to be generated .

Returned data: 00 represents command is executed successfully; 01 represents the storage device is full already; 02 represents command execution failed.

**Note: Here the file name can't be more than 8 characters.**

**4.3.18. Specify recording(of a file) by indexed sequence in a folder**

Start Code	Number	Command	Folder Name(from MSB to LSB)					File Index(from MSB to LSB)		Check Code	End Code
7E	0A	D7	4D (M)	55 (U)	53 (S)	49 (I)	43 (C)	00	02	64	7E

This command is to record a file by indexed sequence in a folder. The folder name(MUSIC) uses ASCII code to indicate, and the hex codes 4D, 55, 53, 49 and 43 respectively correspond to the characters MUSIC. "00 02" represent the 2<sup>nd</sup> recording file in the folder, so it means the 2<sup>nd</sup> recording file(RE002.mp3) is going to be generated in the folder named MUSIC.

Returned data: 00 represents command is executed successfully; 01 represents the storage device is full already; 02 represents command execution failed.

**Note: 1). Here the folder name must be 5 characters. 2). Here the default recording file name format is RExxx.mp3. As the example above, the recording file name is RE002.mp3. It supports to record maximum 999 files(RE001-RE999).**

**4.3.19. Specify recording(of a file) by file name in a folder**

Start Code	Number	Command	Folder Name(from MSB to LSB)					File Name(from MSB to LSB)				Check Code	End Code
7E	0C	D8	4D (M)	55 (U)	53 (S)	49 (I)	43 (C)	54 (T)	30 (0)	30 (0)	32 (2)	4B	7E

This command is to record a file by file name in a folder. The folder name(MUSIC) and the file name(T002) uses ASCII code to indicate. The hex codes 4D, 55, 53, 49 and 43 respectively correspond to the characters MUSIC, and 54, 30, 30, and 32 respectively correspond to the characters T002. So it means the recording file named T002.mp3 is going to be generated in the folder named MUSIC .

Returned data: 00 represents command is executed successfully; 01 represents the storage device is full already; 02 represents command execution failed.

**Note: Here the folder name must be 5 characters and the file name can't be more than 8 characters.**

#### 4.3.20. Stop recording

Start Code	Number	Command	Check Code	End Code
7E	03	D9	DC	7E

This command is to stop recording and generate a recording file.

Returned data: 00 represents command is executed successfully; 01 represents command execution failed;

#### 4.3.21. Delete a specified file in the storage device by indexed sequence

Start Code	Number	Command	File Index(from MSB to LSB)		Check Code	End Code
7E	05	DA	00	02	E1	7E

This command is to delete a sound file in the storage device by indexed sequence. "00 02" represents the 2<sup>nd</sup> sound file, so the 2<sup>nd</sup> sound file(or 0002.mp3) by physical sequence in the root of the storage device is going to be deleted.

Returned data: 00 represents the command is executed successfully; 01 represents no this file.

#### 4.3.22. Delete a specified file in the storage device by file name

Start Code	Number	Command	File Name(from MSB to LSB)				Check Code	End Code
7E	07	DB	54(T)	30(0)	30(0)	32(2)	C8	7E

This command is to delete a sound file in the storage device by file name. The hex codes 54, 30, 30, and 32

correspond to the ASCII codes T002 respectively, so it means the file named T002.mp3 in the root of the storage device is going to be deleted.

Returned data: 00 represents the command is executed successfully; 01 represents no this file.

#### 4.3.23. Delete a specified file in a folder by indexed sequence

Start Code	Number	Command	Folder Name(from MSB to LSB)					File Name(from MSB to LSB)				Check Code	End Code
7E	0A	DC	4D	55	53	49	43	00	02			69	7E
			(M)	(U)	(S)	(I)	(C)						

This command is to delete a sound file in a folder by indexed sequence. Here the folder name uses ASCII code to indicate. The hex codes 4D, 55, 53, 49 and 43 respectively correspond to the characters MUSIC, so it means the 2<sup>nd</sup> sound file(or 0002.mp3) in the folder named MUSIC is going to be deleted.

Returned data: 00 represents the command is executed successfully; 01 represents no this file.

#### 4.3.24. Delete a specified file in a folder by file name

Start Code	Number	Command	Folder Name(from MSB to LSB)					File Name(from MSB to LSB)				Check Code	End Code
7E	0C	DD	4D	55	53	49	43	54	30	30	32	50	7E
			(M)	(U)	(S)	(I)	(C)	(T)	(0)	(0)	(2)		

This command is to delete a sound file in a folder by file name. Here both the folder name(MUSIC) and the file name use ASCII code to indicate. The hex codes 4D, 55, 53, 49 and 43 respectively correspond to the characters MUSIC, and 54, 30, 30 and 32 respectively correspond to the characters T002, so it means the sound file named T002.mp3 in the folder named MUSIC is going to be deleted.

Returned data: 00 represents the command is executed successfully; 01 represents no this file.

#### 4.3.25. Delete all of the files in the storage device

Start Code	Number	Command	Check Code	End Code
7E	03	DE	E1	7E

This command is to delete all of the sound files in the storage device(SD card or USB flash drive)

Returned data: 00 represents command is executed successfully; 01 represents command execution failed;

#### 4.3.26. Delete all of the files in the specific folder

Start Code	Number	Command	Folder Name(from MSB to LSB)					Check Code	End Code
			4D (M)	55 (U)	53 (S)	49 (I)	43 (C)		
7E	08	DE	4D (M)	55 (U)	53 (S)	49 (I)	43 (C)	67	7E

This command is to delete all of the sound files in the specific folder in the storage device.

Returned data: 00 represents command is executed successfully; 01 represents command execution failed;

### 4.4. Detailed Annotation of Query Commands

#### 4.4.1. Query current volume level

Start Code	Number	Command	Check Code	End Code
7E	03	C1	C4	7E

Operation Code	Returned Data
0XC1	00-1F(Volume Value)

#### 4.4.2. Query current work status

Start Code	Number	Command	Check Code	End Code
7E	03	C2	C5	7E

Operation Code	Returned Data
0XC2	01: Playing 02: Stopped 03: Paused 04: Recording 05: Fast forward/backward

#### 4.4.3. Query the total file numbers in the root directory

Start Code	Number	Command	Check Code	End Code
7E	03	C5	C8	7E

Operation Code	Returned Data
0XC5	Total file numbers(hexadecimal)

#### 4.4.4. Query the total file numbers in the specified folder in the storage device

Start Code	Number	Command	Folder Name(from MSB to LSB)					Check Code	End Code
7E	08	C6	4D (M)	55 (U)	53 (S)	49 (I)	43 (C)	4F	7E

Operation Code	Returned Data
0XC6	Total file numbers(hexadecimal)

#### 4.4.5. Query current sound file being played

Start Code	Number	Command	Check Code	End Code
7E	03	C9	CC	7E

Operation Code	Returned Data
0XC9	0001(for example)

**Note: 0001 represents the sound file 0001.mp3 actually.**

#### 4.4.6. Query current connection status regarding SD card and USB flash drive

Start Code	Number	Command	Check Code	End Code
7E	03	CA	CD	7E

Operation Code	Returned Data
0XCA	00/01/02/03

When SD card or USB flash drive is pulled out, FN-RM01 returns related data automatically to prompt. Also users can send the command 0xCA as above to query the connection status. The meaning of returned data is as below.

- 00: both SD card and USB flash drive connected;
- 01: SD card connected only;
- 02: USB flash drive connected only;
- 03: neither SD card nor USB flash drive connected;



**4.4.7. Query whether a sound file is in the root directory of the storage device**

Start Code	Number	Command	File Name(from MSB to LSB)				Check Code	End Code
7E	07	CB	54(T)	30(0)	30(0)	32(2)	B8	7E

Returned data: 00 represents the file exists; 01 represents no this file

**4.4.8. Query whether a sound file is in a folder**

Start Code	Number	Command	Folder Name(from MSB to LSB)					File Name(from MSB to LSB)				Check Code	End Code
7E	0C	CC	4D (M)	55 (U)	53 (S)	49 (I)	43 (C)	54 (T)	30 (0)	30 (0)	32 (2)	3F	7E

Returned data: 00 represents the file exists; 01 represents no this file

**4.4.9. Query the file name of the sound file currently playing**

Start Code	Number	Command	Check Code	End Code
7E	03	CD	D0	7E

Operation Code	Returned Data
0XCD	XX XX XX XX

**4.4.10. Query space left in the storage device**

Start Code	Number	Command	Check Code	End Code
7E	03	CE	D1	7E

Operation Code	Returned Data
0XCE	XXXX capacity left (Mb)

**4.4.11. Notes for Using Serial Commands**

1). During recording, if the storage device(SD card or USB flash drive) is full, the module will automatically stop recording and return the data 01 00 to warn.

- 2). When a recording file is needed to be deleted, please don't disconnect power or pull out the storage device, otherwise the recording files or even the file system will probably get damaged.
- 3). During sending serial commands, please delay 100ms at least between two commands.

## 5. Applications Circuits

### 5.1. Connection for ADKEY Control

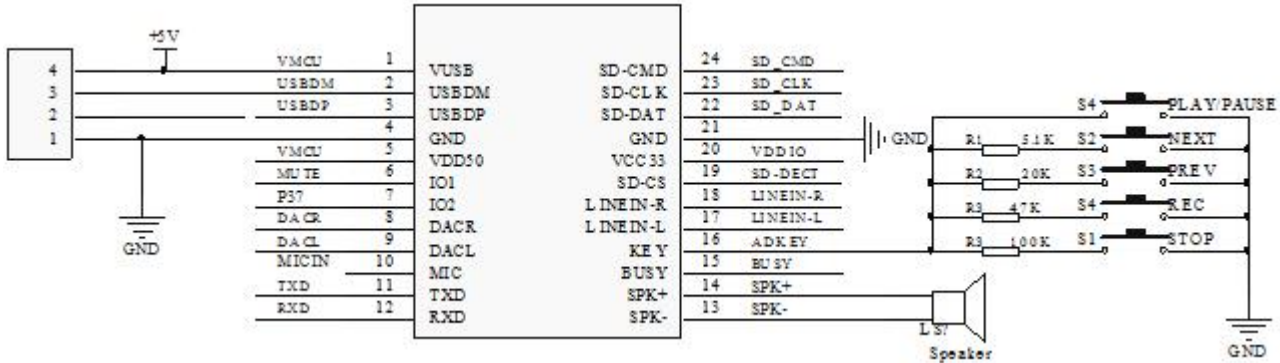

**Note:** As you can see from the diagram above, except the key Play/Pause that doesn't need a resistor, each key needs a specific value of the resistor.

For Next: a 5.1K resistor

For Previous: a 20K resistor

For Record: a 47K resistor

For Stop: a 100K resistor

### 5.2. Connection for MIC recording and USB flash drive

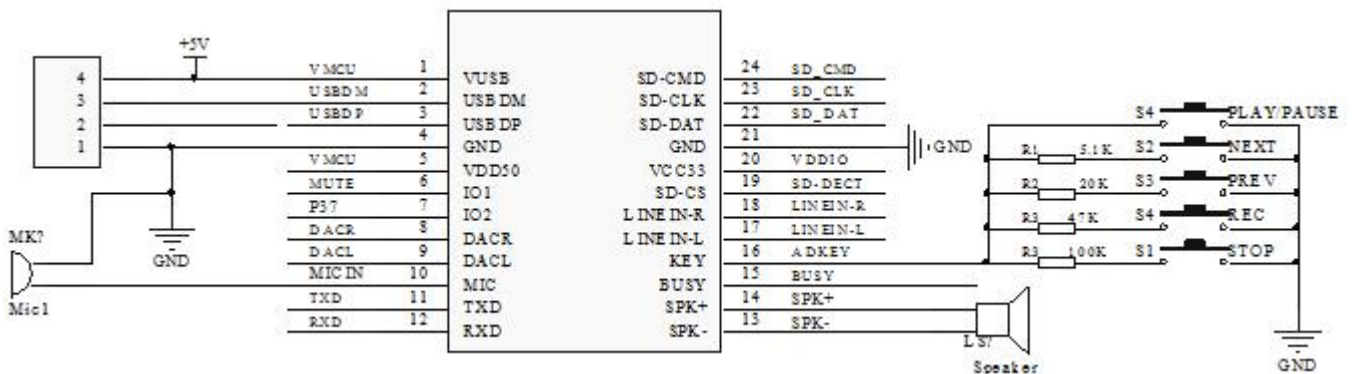

### 5.3. Connection for Line-in recording

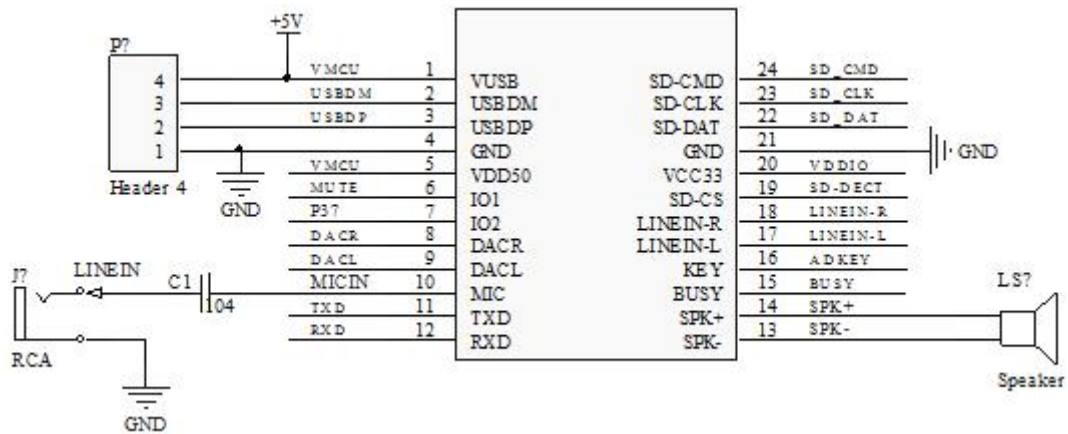

### 5.4. Connection for Aux-in Recording

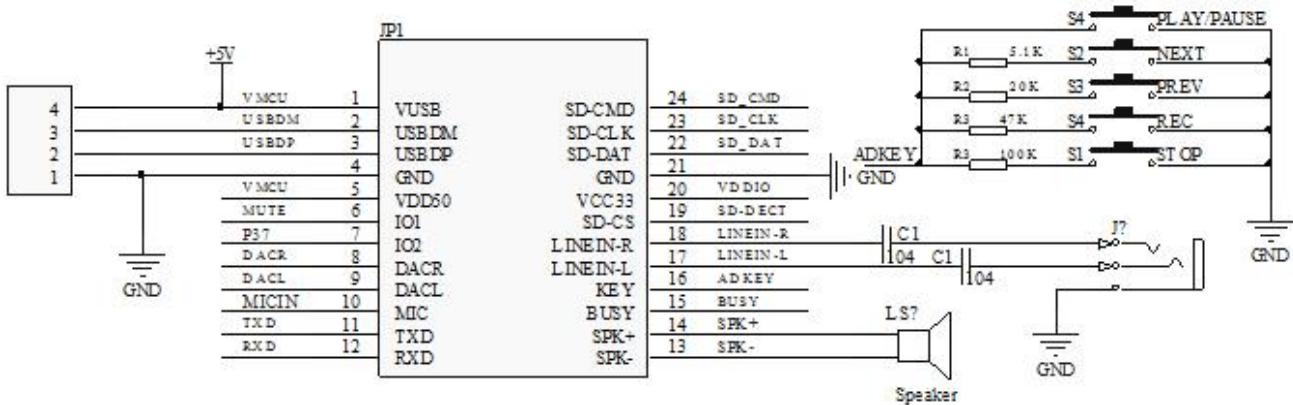

#### Notes:

- 1). As the working voltage of the I/O ports(TXD&RXD) is 3.3V, it can be direct connected with a 3.3V MCU.
- 2). If use a 5V MCU, RXD needs to be current-limited and TXD needs to be separated with a diode.
- 3). When use Aux-in for stereo audio recording, the external input signal needs to be within 2.8V, otherwise it fails to record.

## 6. GPIO Features

Description	Function	Min. Value	Typical Value	Max. Value	Unit	Condition
VDD50	LDO Input Voltage	3.2	5.0	5.5	V	-
VCC33	LDO3.3V Input current	-	-	150	mA	Vout3.3>3.1V
SNR	SNR	-	92	-	dB	-

THD+N	Total harmonic distortion	-	-70	-	dB	No-load
PWRAB	DAC output power	-	-	16	mW	16Ω load, mono
Vpp	DAC Max. Output amplitude voltage	-	-	2.8	V	-
Psi	Standby consumption(with micro SD card)	-	27.6	-	mA	related to power consumption of micro SD card
Prec	Standby consumption(with micro SD card)	-	28.1	-	mA	Same as above
P	Consumption during playback( with load)	-	28.7	-	mA	Same as above
Vppline	External audio input	-	-	2.8	v	-

## 7. PCB Size

