

C329-SPI User Manual

Release Note:

V1.0 27th September, 2010 First release

V1.1 12th January 2012 Second release

General Description

The C329 is a colour VGA camera module which performs JPEG compression and can be attached to a host via an SPI interface. Users can send a Snapshot command from the host in order to capture an image. The image is then compressed by the host and stored in an internal buffer and transferred to the host through the SPI port.

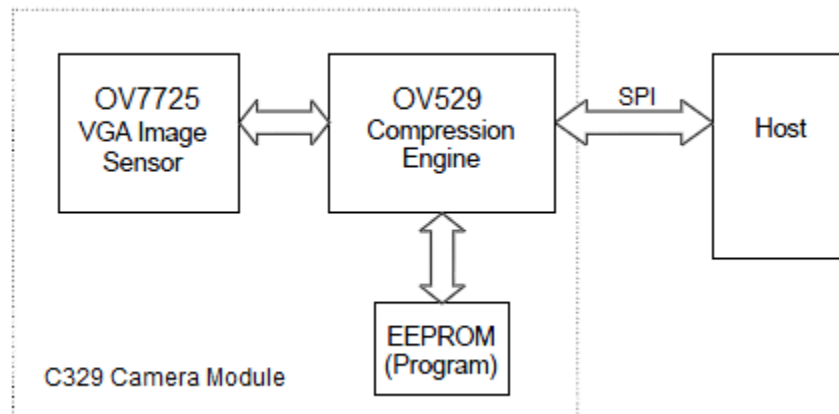

Figure 1 – System Block Diagram

Features

- Small Size, 20x28mm
- Adjustable resolution resolution, Max VGA
- 3.3V operation
- Low Power consumption 64mA active
- SPI Interface with Hold
- Power Saving Mode
- Multiple lens options
- Multiple interface options (UART version available)

System Configuration

Camera Sensor

The C329 uses a 1/4" OmniVision VGA sensor with an 8-bit YcbCr interface and 3.8 V/(Lux Sec) sensitivity.

OV529 Serial Bridge

The OV529 Serial bridge contains an Embedded JPEG CODEC and controller chip that can compress and transfer image data from the Camera Sensor to an external device. The OV529 performs all imaging function like white balance, downsizing and compressed image storage.

Program EEPROM

A Serial EEPROM provides the program code that gives the OV529 its interface and command set.

Board Layout

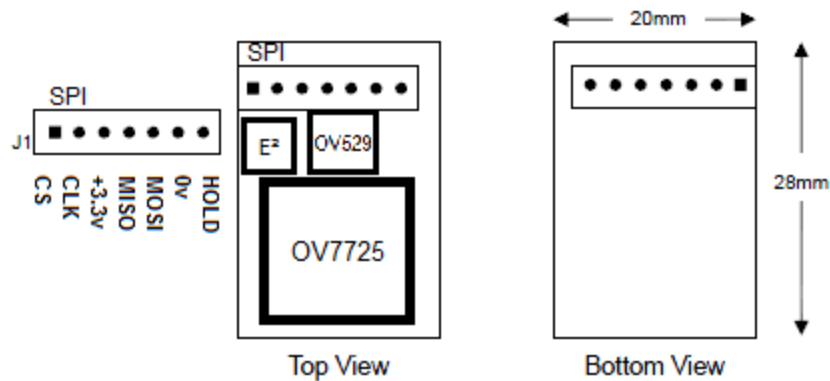
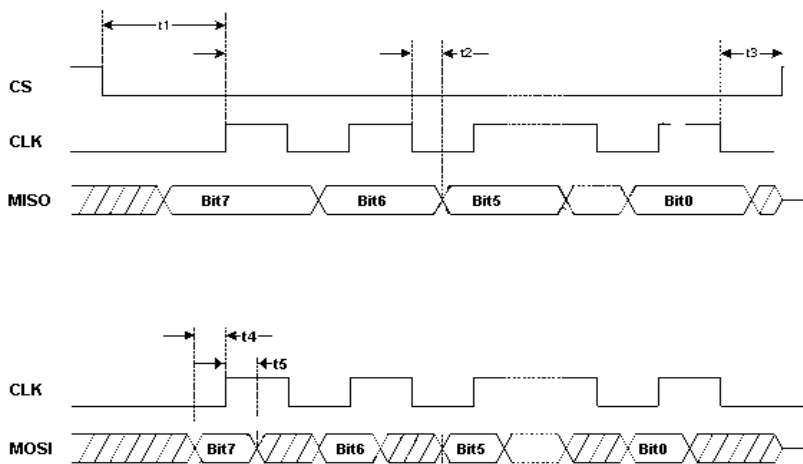

Figure 2 – C329-SPI board Layout and Serial Interface

SPI Interface

Timing Options and CLK

The SPI interface consists of MOSI (Master Out Slave In), MISO (Master In Slave Out), CLK and CS. In the OV529 there is the addition of HOLD which when H indicates to the Master that the OV529 isn't ready and should hold off the next transaction. The CS signal allows multiple devices to be attached to the SPI bus. When CS is L the OV529 is selected. Data on MISO will be clocked out on the falling edge of CLK and data on MOSI will be clocked in on the rising edge of CLK. (It is possible to select both clock edges, this will require a hardware change that must be ordered specifically. It is recommended to use the above scenario if at all possible)



(unit: ns)

	Min	Typ	Max	Description
t1	200			Chip enable setup time
t2	10		12	MISO hold time
t3	12			Chip enable hold time
t4	12			MOSI setup Time
t5	12			MOSI hold time

Figure 3 – SPI Timing

Command Set

The C329-SPI module supports the following commands:

Command	Cmd Token	Parameter 1	Parameter 2	Parameter 3	Parameter 4
INITIAL	FFFFFF01h	00h	Colour Type	Preview Res.	Compres. Res
GET PIC	FFFFFF04h	Pic. Type	00h	00h	00h
SNAPSHOT	FFFFFF05h	Snapshot Type	00h	00h	00h
RESET	FFFFFF08h	Reset Type	00h	00h	00/FFh
POWER OFF	FFFFFF09h	00h	00h	00h	00h
DATA	FFFFFF0Ah	Data Type	Length Byte 0	Length Byte 1	Length Byte 2
SYNC	FFFFFF0Dh	00h	00h	00h	00h
ACK	FFFFFF0Eh	Cmd Token	ACK counter	00h	00h
NAK	FFFFFF0Fh	00h	NAK counter	Err. Number	00h
QUALITY	FFFFFF10h	Quality Level	00h	00h	00h

INITIAL (FFFFFF01h)

Colour Type

Colour Type	Description
02h	Y4
03h	Y8
05h	RGB12
06h	RGB16
08h	RGB24
09h	YUV16
07h	Compression

Preview Resolution

Preview Resolution	Description
01h	80x60
02h	88x72
03h	160x120
04h	176x144
05h	320x240
06h	352x288
07h	640x480
08h	80x64
09h	128x96
0Ah	128x128
0Bh	160x128

Compression Resolution

Compression Resolution	Description
01h	80x60
02h	88x72
03h	160x120
04h	176x144
05h	320x240
06h	352x288
87h	640x480
08h	80x64
09h	128x96
0Ah	128x128
0Bh	160x128

GET PIC (FFFFFF04h)Picture Type

Picture Type	Description
01h	Snapshot Picture
02h	Preview Picture
03h	Serial Flash Picture
05h	Compression Preview Picture
06h	Playback Picture

SNAPSHOT (FFFFFF05h)

The host sends this command to ask OV529 to capture a still image. Snapshot Type must be 0 in order to be compatible with OV528.

RESET (FFFFFF08h)

Reset All means a reset of the whole system, including registers and state machines. uC will be rebooted. Reset State Machine means a reset of some state machines only. When the last byte of Reset command is FFh, the OV529 must stop the current job and perform this Reset command immediately.

Reset Type

Reset Type	Description
00h	Reset All
01h	Reset State Machine

POWER OFF (FFFFFF09h)

The host sends this command to suspend OV529.

DATA (FFFFFF0Ah)

The C329 sends this command to pass the length of the stored image. The following kinds of data

must be preceded by Data command to provide the data length information. Length byte 0 is Least Significant Byte (LSB), and Length byte 2 is Most Significant byte (MSB).

Data Type

Data Type	Description
00h	Register Data
01h	Snapshot Picture
02h	RGB/YUV/Preview Picture
04h	Compression Preview Picture
05h	Playback Picture

Length

Image Length = len 0 + Len 1 * 100h + Len 2 * 10000h

SYNC (FFFFFF0Dh)

The host sends this command to start a synchronization sequence.

ACK (FFFFFF0Eh)

This command is a handshake command to indicate that previous transaction was succeeded.

Command ID

The received command ID.

ACK Counter

The host and OV529 maintain their own ACK counters. After transmitting an ACK command, this counter will be increased by 1.

NAK (FFFFFF0Fh)

This command is a handshake command, which indicates corrupted transmissions or unsupported features.

NAK Counter

The host and OV529 maintain their own NAK counters. After transmitting an NAK command, this counter will be increased by 1.

Error Number

The error condition number

QUALITY (FFFFFF10h)

The host sends this command to select image quality level. Image quality level only effects Compression related images. No influence on image of bypass mode.

Quality Level

Quality Level	Description
00h	Best
01h	Better
02h	Normal

Command Implementation

Power On & Power Off

OV529 camera system requires around 1 second from power off to next power on. After power on, the camera requires around 1.2 second for firmware load from EEPROM and system wake up.

SYNC

The Remote System sends a SYNC command and awaits an ACK, the C329 then sends out its own SYNC and the Remote system is expected to respond with an ACK as shown below.

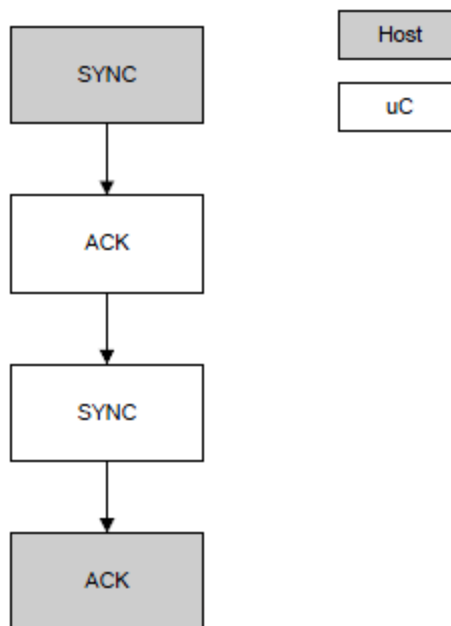

Commands

The Following commands respond with ACK: INITIAL, RESET, SNAPSHOT, POWER OFF and SELECT IMAGE QUALITY as shown below.

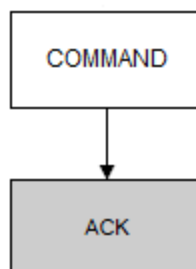

GET PICTURE

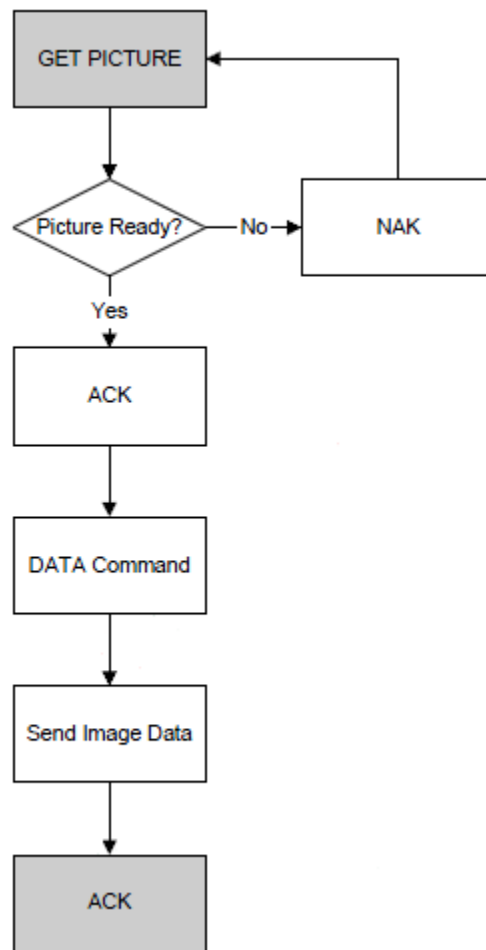

Code Implementation

Here is an example of how to SYNC with the C329:

- Send Get SYNC command. (FFFFFF0D00000000h)
- Wait 25ms
- Did we get ACK (FFFFFF0E0Dnn0000h)? If NO repeat above command up to 60 times.
- Did we get SYNC? If NO repeat above.
- Send ACK command.

Here is an example of how to establish communication with the C329 for the first time:

- Set Remote Baud Rate to 14,400 bps
- Get SYNC
- Change C329 Baud Rate with command (FFFFFF0100870107h)
- Set Remote Baud Rate to new BAUD (921,600) in this example.
- Get SYNC

Here is an example of the commands required to quickly capture and transfer an image from the C329 to an embedded system:

- Establish communication as above.
- Send command INIT (FFFFFFF0100870107h)
- GET ACK (FFFFFF0E01nn0000h)
- Send command SELECT IMAGE QUALITY (FFFFFF1000000000h)
- GET ACK (FFFFFF0E10nn0000h)
- Send command GET PICTURE (FFFFFF0405000000h)
- GET ACK (FFFFFF0E04nn0000h)
- GET ACK (FFFFFF0AnnL0L1L2h)
- GET Image Data